



## 10AC SERIES UNITS

The 10AC is a high-efficiency residential split-system condensing unit. Extra large condensing coil, coil circuiting and high condenser air volume result in a high SEER rating (minimum of 10.0). The series is designed for use with an expansion valve or RFCII system in the indoor unit.

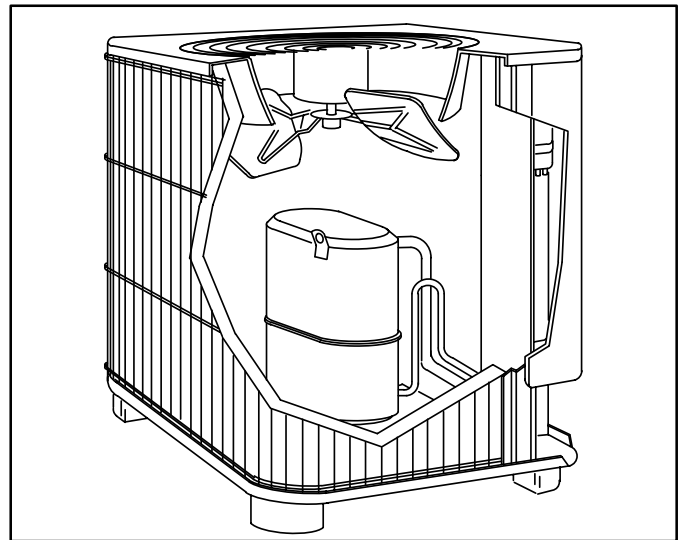
All compressors are hermetically sealed for trouble-free operation and long service life. Compressor components are spring mounted within the sealed housing. The compressor is installed in the unit on resilient rubber mounts to assure quiet, vibration-free operation. A built-in protection device assures protection from excessive current and temperatures.

10AC48 through 10AC60 models are furnished with crankcase heaters as standard equipment to assure proper compressor lubrication at all times. The heater is temperature actuated and operates only when required.

Several models are available in sizes ranging from 1 through 5 tons.

This manual is divided into sections which discuss the major components, refrigerant system, charging procedure, maintenance and operation sequence.

All specifications in this manual are subject to change.



### SPECIFICATIONS

Model No.		10AC12	10AC18	10AC24	10AC30-1	10AC30-2
Condenser Coil	Net face area (sq. ft.)	12.60	12.60	12.60	14.70	
	Tube diameter (in.) & no. of rows	3/8 — 1	3/8 — 1	3/8 — 1	3/8 — 1	
	Fins per inch	20	20	20	20	
Condenser Fan	Diameter (in.) & no. of blades	20 — 3	20 — 3	20 — 3	20 — 3	
	Motor hp	1/6	1/6	1/6	1/6	
	Cfm	2500	2500	2500	2700	
	Rpm	850	850	850	850	
	Watts	200	200	200	205	
	Full load amps	1.1	1.1	1.1	1.1	
**Refrigerant — 22 charge furnished		4 lbs. 4 oz.	4 lbs. 12 oz.	5 lbs. 5 oz.	5 lbs. 9 oz.	
Liquid line (o.d. in.) connection (sweat)		† 3/8	†† 3/8	†† 3/8	3/8	
Suction line (o.d. in.) connection (sweat)		1/2	5/8	5/8	3/4	
Line voltage data — 60 hz		208/230v - 1ph				
Compressor rated load amps		5.0	8.6	9.8	12.2	13.7
Rec. max. fuse or circuit breaker size (amps)		15	20	20	25	30
*Minimum circuit ampacity		7.4	12.0	13.4	16.4	18.2

\*Refer to National Electric Code manual to determine wire, fuse and disconnect size requirements.

\*\*Refrigerant charge sufficient for 20 ft. length of refrigerant lines.

† 3/8" x 1/4" reducer furnished to adapt to 1/4" field fabricated line set.

†† 3/8" x 5/16" reducer furnished to adapt unit to 5/16" line set.

NOTE — Extremes of operating range are plus 10% and minus 5% of line voltage.

**SPECIFICATIONS (continued)**

Model No.		10AC36	10AC42-1	10AC42-2	10AC48	10AC60
Condenser Coil	Net face area (sq. ft.)	Outer coil	14.70	14.70	20.0	20.0
		Inner coil	----	9.80	----	15.40
	Tube diameter (in.) & no. of rows		3/8 — 1	3/8 — 1.67	3/8 — 1	3/8 — 1.77
	Fins per inch		20	20	20	20
Condenser Fan	Diameter (in.) & no. of blades		20 — 3	20 — 3	24 — 4	24 — 4
	Motor hp		1/6	1/6	1/4	1/4
	Cfm		2700	2450	3900	4000
	Rpm		840	840	835	830
	Watts		205	210	340	355
	Full load amps		1.1	1.1	1.7	1.7
**Refrigerant — 22 charge furnished		5 lbs. 12 oz.	9 lbs. 3 oz.	7 lbs. 13 oz.	8 lbs. 13 oz.	11 lbs. 2 oz.
Liquid line (o.d. in.) connection (sweat)		3/8	3/8		3/8	3/8
Suction line (o.d. in.) connection (sweat)		3/4	7/8		7/8	7/8
Line voltage data — 60 hz		208/230v - 1ph				
Compressor rated load amps		16.3	22	20.3	22.5	30.8
Rec. max. fuse or circuit breaker size (amps)		35	50	45	50	60
*Minimum circuit ampacity		21.5	28.6	27.0	30.0	40.2

\*Refer to National Electric Code manual to determine wire, fuse and disconnect size requirements.

\*\*Refrigerant charge sufficient for 20 ft. length of refrigerant lines.

NOTE — Extremes of operating range are plus 10% and minus 5% of line voltage.

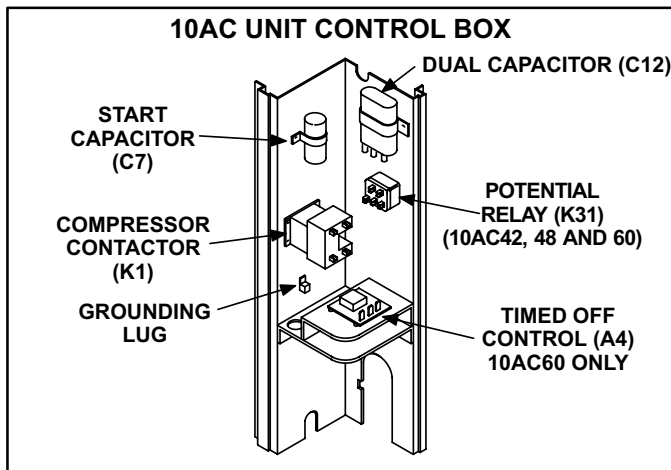
**I - UNIT INFORMATION**

10AC condensing units are available in 1, 1 -1/2, 2, 2 -1/2, 3, 3 -1/2, 4 and 5 ton capacities.

All major components (indoor blower/coil) must be matched according to Lennox recommendations for the compressor to be covered under warranty. Refer to the Engineering Handbook for approved system matchups. A misapplied system will cause erratic operation and can result in early compressor failure.

**II - UNIT COMPONENTS**

**A - Control Box (Figure 1)**



**FIGURE 1**

**⚠ DANGER**



**Shock Hazard**

10AC units use single-pole contactors. One leg of compressor, capacitor and condenser fan are connected to line voltage at all times. Potential exists for electrical shock resulting in injury or death. Remove all power at disconnect before servicing.

Can cause personal injury or death.

**1 - Compressor Contactor K1**

The compressor is energized by a SPST contactor located in the control box. See figure 1. The contactor is energized by indoor thermostat terminal Y when thermostat demand is present.

The contactor coil is energized by 24VAC supplied by the indoor unit. All other controls in the outdoor unit are powered by line voltage. Refer to unit wiring diagram. 10AC units are not equipped with a line voltage to 24V transformer.

## 2 - Dual Capacitor C12

The compressor and fan in all units use permanent split capacitor motors. The capacitor is located inside the unit control box (see figure 1). A single “dual” capacitor (C12) is used for both the fan motor and the compressor (see unit wiring diagram). The fan side and the compressor side of the capacitor have different MFD ratings. See table 1 for dual capacitor ratings.

**TABLE 1**

10AC (C12) DUAL CAPACITOR RATING			
Unit	Terminal	MFD	VAC
10AC12	FAN	5	370
10AC18	HERM	25	
10AC24	FAN	5	
	HERM	30	
10AC30-1 10AC36	FAN	5	
	HERM	45	
10AC30-2	FAN	5	
	HERM	35	
10AC42-1	FAN	5	
	HERM	50	
10AC42-2 10AC48	FAN	10	440
	HERM	45	
10AC60	FAN	10	
	HERM	60	

## 3 - Start Capacitor C7

All 10AC42, 48 and 60 units use a start capacitor (C7) wired in parallel with the compressor side of the dual capacitor. The capacitor is located inside the unit control box (see figure 1). C7 is switched off by potential relay (K31) when the compressor nears full speed. See table 2 for start capacitor ratings.

**TABLE 2**

10AC START CAPACITOR RATING		
Unit	MFD	VAC
10AC42-1	189-227	330
10AC42-2 10AC48	135-155	320
10AC60	270-324	330

## 4 - Potential (Start) Relay K31

All 10AC42,48 and 60 units use a potential relay which controls the operation of the starting circuit. The potential relay is located inside the unit control box (see figure 1). The relay is normally closed when contactor K2 is de-energized. When K1 energizes, the compressor immediately begins start-up. K31 remains closed during compressor start-up and the start capacitor remains in the circuit. As the compressor gains speed, K31 is energized. When K31 energizes, the contacts open and the start capacitor is taken out of the circuit.

## 5 - Timed Off Control A4

A time delay (A4) located in the control box is used on the 10AC60. See figure 1. The time delay is electrically connected between thermostat terminal Y and the compressor contactor. After cooling demand has stopped,

A4 begins counting for five minutes. During the timing period, A4 disables the compressor contactor. Thermostat demand will have no effect on the unit. The unit cannot operate. After the delay, the compressor contactor can be energized.

# ⚠ DANGER

**Do not attempt to repair this control. Unsafe operation will result. If the control has failed, replace the control.**

## B - Compressor

Table 3 shows specifications of compressors used in 10AC units.

**TABLE 3**

10AC COMPRESSOR SPECIFICATIONS					
Unit	Voltage	Phase	LRA	RLA	Oil fl. oz.
10AC12	208/230	1	26.3	4.8	15**
10AC18	208/230	1	49.0	9.6	45*
10AC24	208/230	1	56.0	10.9	45*
10AC30-1	208/230	1	71.0	11.7	32*
10AC30-2	208/230	1	75.0	13.7	32*
10AC36	208/230	1	86.7	14.2	54*
10AC42-1	208/230	1	105.0	16.4	70*
10AC42-2	208/230	1	107.4	20.3	54*
10AC48	208/230	1	110.0	20.5	54*
10AC60	208/230	1	147.0	24	65*

\*Shipped with conventional white oil (Sontex 200LT) or 3GS. 3GS oil may be used if additional oil is required.

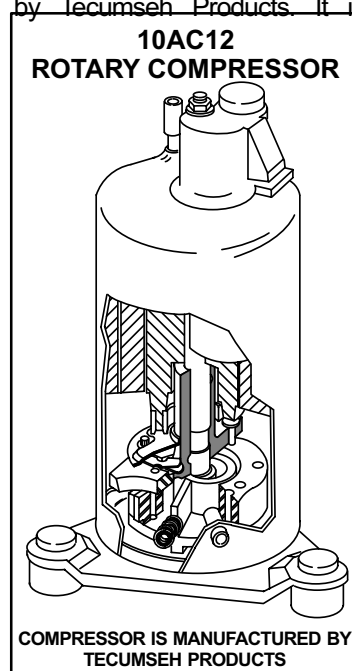
\*\*Shipped with 60% Zerol 300—40% Sontex 200LT. Zerol 300/Sontex 200LT may be used if additional oil is required.

## 1 - Rotary Compressor (10AC12 Units Only)

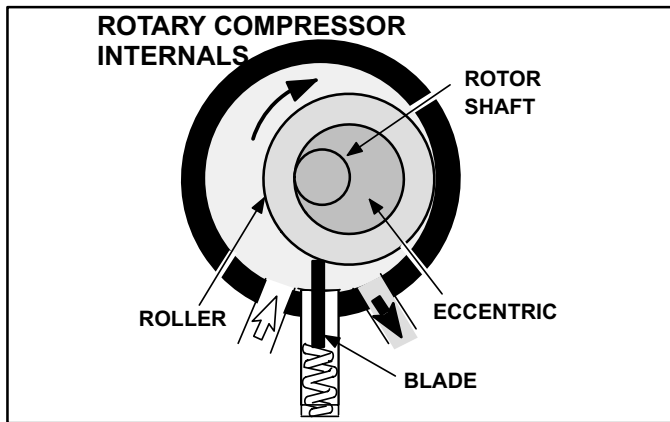
10AC12 units utilize a hermetically sealed rotary-type compressor manufactured by Tecumseh Products. It is illustrated in figure 2.

The compressor has four moving parts: a rotor shaft, eccentric, roller and a blade. See figure 3.

The compressor rotor shaft is attached directly to the compressor motor. The rotor shaft is permanently attached to an eccentric. The eccentric is inside the roller and as the eccentric rotates, the roller rotates. The spring loaded blade is in continuous contact with the roller. The contact and a thin layer of oil form a seal separating the suction port from the discharge port at all times.

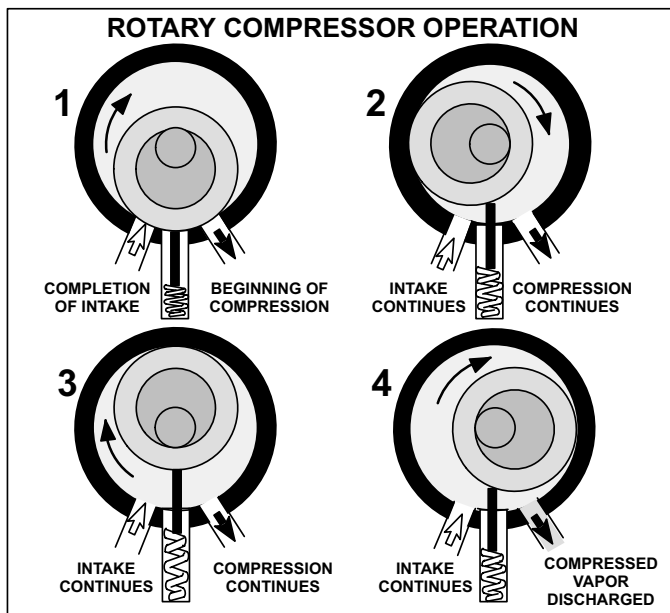


**FIGURE 2**



**FIGURE 3**

Figure 4 illustrates the four steps in a rotary compressor's continuous intake cycle. The spring-loaded blade is compressed fully at the beginning of an exhaust cycle. At this instant the compression is beginning (1). The roller rotates and compression continues (2). The suction port is always separated from the discharge port (3). Intake continues and the compressed vapor is discharged (4).



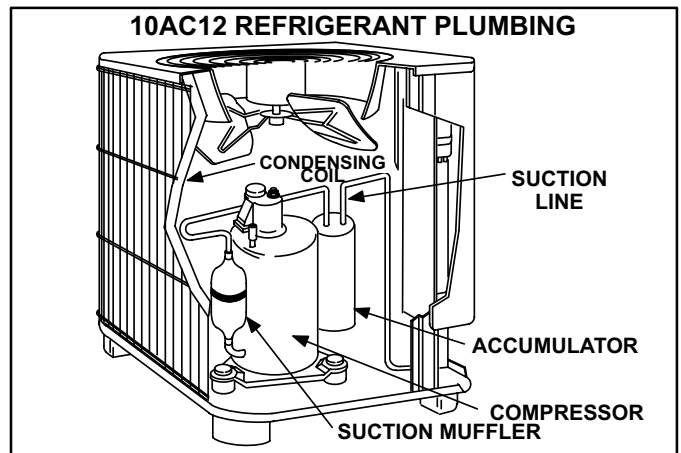
**FIGURE 4**

**a - Suction Muffler ( 10AC12 Units Only)**

All 10AC12 units are equipped with a suction muffler that is externally mounted on the compressor shell and attaches to the suction line. The muffler contains two wire mesh filters for added compressor protection. See figure 5.

**2 - Accumulator (10AC12 Units Only)**

All 10AC12 units are equipped with an accumulator that is mounted in the suction line. The accumulator protects the compressor from liquid slugging. See figure 5.



**FIGURE 5**

**3 - Reciprocating Compressor (all other units)**

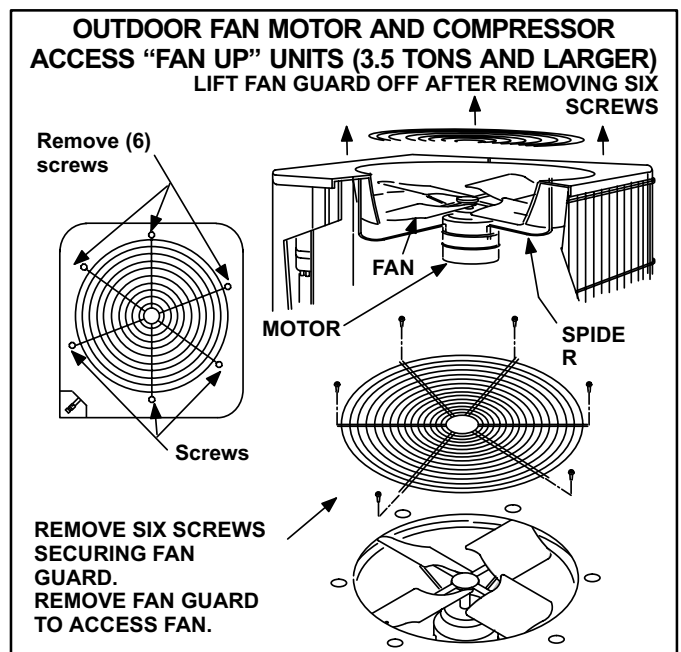
All units except for the 10AC12 utilize a conventional reciprocating style compressor.

**4 - Crankcase Heater**

A crankcase heater is used on all 10AC48 and 10AC60 units. The well-mounted insertion-type heater is self-regulating. Heaters are rated at 27 watts for 10AC48 and 30 watts for 10AC60. The heater is temperature actuated and operates only when required.

**C - Condenser Fan Motor**

All units use single-phase PSC fan motors which require a run capacitor. The table on page 1 of this manual shows the specifications of condenser fans used in 10AC units. The condenser fan is controlled by the compressor contactor. Two different mounting arrangements are used (fan up and fan motor up) see figures 6 and 7.



**FIGURE 6**

Access to the condenser fan motor on all units is gained by removing the six (6) screws securing the fan guard. See figures 6 and 7.

The condenser fan motor is attached to the fan guard on "motor up" units and is removed with the fan guard. See figure 7.

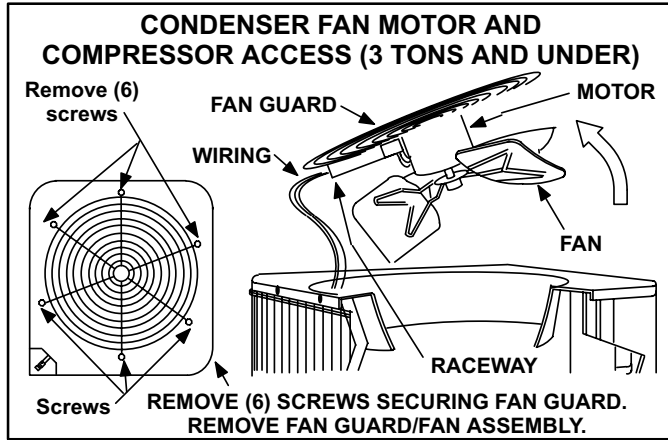


FIGURE 7

### III - REFRIGERANT SYSTEM

#### A - Plumbing

Field refrigerant piping consists of liquid and suction lines from the outdoor unit (sweat connections). Use Lennox L10 series line sets as shown in table 4 or field fabricated refrigerant lines.

Separate discharge and suction service ports are provided outside the unit for connection of gauge manifold during charging procedure.

TABLE 4

LINE SET				
Condensing Unit Model No.	SPECIFICATIONS Set Model No.	Length of Suct. & Liq. Lines (ft.)	Liquid Line (o.d. ft.)	Suction Line (o.d. ft.)
10AC12	*Not Available	---	**1/4	1/2
10AC18	L10-21-20	20	***5/16	5/8
	L10-21-25	25	***5/16	5/8
10AC24	L10-21-35	35	***5/16	+5/8
	L10-21-50	50	***5/16	+5/8
10AC30	L10-41-20	20	3/8	3/4
	L10-41-30	30	3/8	3/4
10AC36	L10-41-40	40	3/8	3/4
	L10-41-50	50	3/8	3/4
10AC42	L10-65-30	30	3/8	7/8
	L10-65-40	40	3/8	7/8
10AC48	L10-65-50	50	3/8	7/8
10AC60	*Not Available	---	3/8	1-1/8

\*Field Fabricate  
 \*\*3/8" x 1/4" reducer furnished to adapt unit to 1/4" field fabricated line set.  
 \*\*\* 3/8" x 5/16" reducer furnished to adapt unit to 5/16" line set.

#### B - Service Valves

The liquid line and suction line service valves and gauge ports are accessible from outside of the unit. Full service liquid and suction line valves are used. See figures 8 and 9. The service ports are used for leak testing, evacuating, charging and checking charge.

### 1 - Liquid Line Service Valve

A full-service liquid line valve made by one of several manufacturers is used on all 10AC units. All liquid line service valves function the same way, differences are in construction. Valves manufactured by Parker are forged assemblies. Valves manufactured by Primore are brazed together. Valves are not rebuildable. If a valve has failed it must be replaced. The liquid line service valve is illustrated in figure 8.

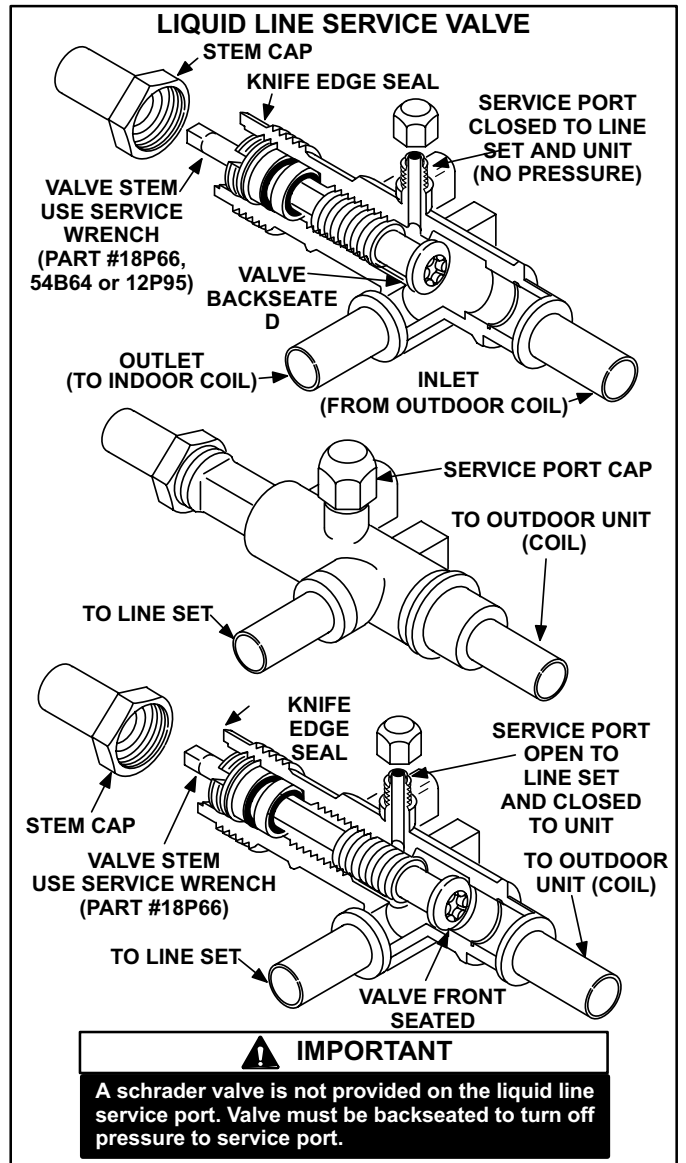


FIGURE 8

The valve is equipped with a service port. There is no schrader valve installed in the liquid line service port. A service port cap is supplied to seal off the port. The liquid line service valve is a front and back seating valve. When the valve is backseated the service port is not pressurized. The service port cap can be removed and gauge connections can be made.

## ⚠ CAUTION

The service port cap is used to seal the liquid line service valve. Access to service port requires backseating the service valve to isolate the service port from the system. Failure to do so will cause refrigerant leakage.

## ⚠ IMPORTANT

A schrader valve is not provided on the liquid line service port. Valve must be backseated to turn off pressure to service port.

### To Access Service Port:

- 1 - Remove the stem cap. Use a service wrench (Part #18P66, 54B64 or 12P95) to make sure the service valve is backseated.
- 2 - Remove service port cap and connect high pressure gauge to service port.
- 3 - Using service wrench, open valve stem (one turn clockwise) from backseated position.
- 4 - When finished using port, backseat stem with service wrench. Tighten firmly.
- 5 - Replace service port and stem cap. Tighten finger tight, then tighten an additional 1/6 turn.

### To Close Off Service Port:

- 1 - Using service wrench, backseat valve.
  - a - Turn stem counterclockwise.
  - b - Tighten firmly.

### To Open Liquid Line Service Valve:

- 1 - Remove the stem cap with an adjustable wrench.
- 2 - Using service wrench, backseat valve.
  - a - Turn stem counterclockwise until backseated.
  - b - Tighten firmly.
- 3 - Replace stem cap, finger tighten then tighten an additional 1/6 turn.

### To Close Liquid Line Service Valve:

- 1 - Remove the stem cap with an adjustable wrench.
- 2 - Turn the stem in clockwise with a service wrench to front seat the valve. Tighten firmly.
- 3 - Replace stem cap, finger tighten then tighten an additional 1/6 turn.

## 2 - Suction Line Service Valve

## ⚠ WARNING

Do not attempt to backseat this valve. Attempts to backseat this valve will cause snap ring to explode from valve body under pressure of refrigerant. Personal injury and unit damage will result.

A full service non-backseating suction line service valve is used on all 10AC units. Different manufacturers of valves may be used. All suction line service valves function the same way, differences are in construction. Valves manufactured by Parker are forged assemblies. Valves manufactured by Primore or Aeroquip are brazed together. Valves are not rebuildable. If a valve has failed it must be replaced. The suction line service valve is illustrated in figure 9.

The valve is equipped with a service port. A schrader valve is factory installed. A service port cap is supplied to protect the schrader valve from contamination and assure a leak free seal.

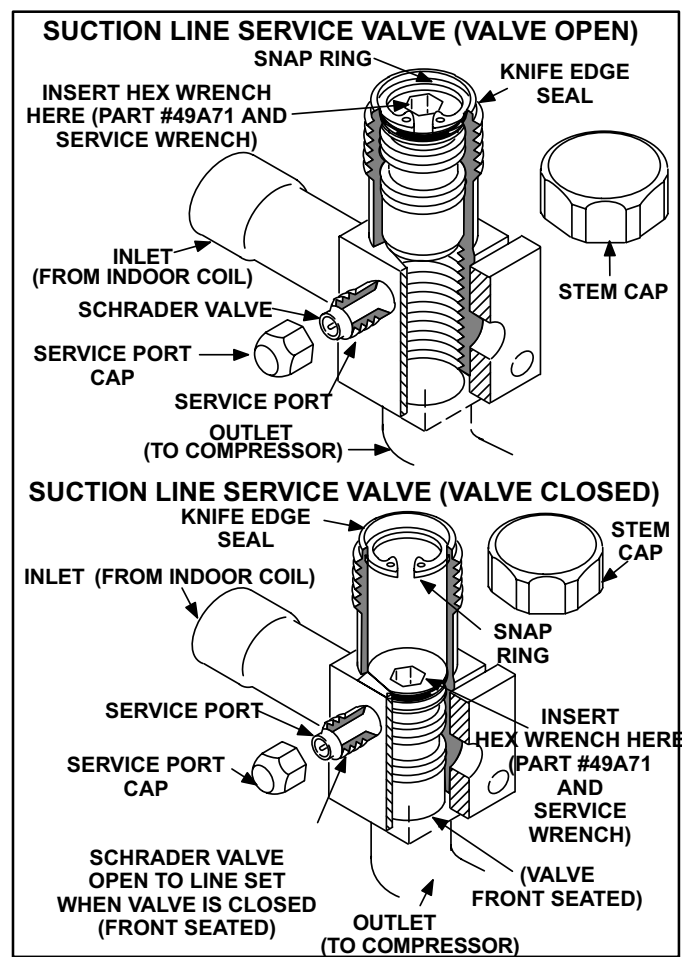


FIGURE 9

### To Access Schrader Port:

- 1 - Remove service port cap with an adjustable wrench.
- 2 - Connect gauge to the service port.
- 3 - When testing is completed, replace service port cap. Tighten finger tight, then tighten an additional 1/6 turn.

### To Open Suction Line Service Valve:

- 1 - Remove stem cap with an adjustable wrench.
- 2 - Using service wrench and 5/16" hex head extension (part #49A71) back the stem out counterclockwise until the valve stem just touches the retaining ring.

## **⚠ DANGER**

**Do not attempt to backseat this valve. Attempts to backseat this valve will cause snap ring to explode from valve body under pressure of refrigerant. Personal injury and unit damage will result.**

- 3 - Replace stem cap tighten firmly. Tighten finger tight, then tighten an additional 1/6 turn.

### To Close Suction Line Service Valve:

- 1 - Remove stem cap with an adjustable wrench.
- 2 - Using service wrench and 5/16" hex head extension (part #49A71) turn stem in clockwise to seat the valve. Tighten firmly.
- 3 - Replace stem cap. Tighten finger tight, then tighten an additional 1/6 turn.

## IV - CHARGING

Unit charge is based on a matching indoor coil and outdoor coil with a 20 foot (6096 mm) line set. For varying lengths of line set, refer to table 5. A blank space is provided on the unit rating plate to list actual field charge.

**TABLE 5**

Liquid Line Set Diameter	Ounce per 5 foot (ml per mm) adjust from 20 ft. (6096mm) line set*
1/4 in. (6 mm)	1 ounce per 5 feet (30 ml per 1524 mm)
5/16 in. (8mm)	2 ounce per 5 feet (60 ml per 1524 mm)
3/8 in. (10 mm)	3 ounce per 5 feet (90 ml per 1524 mm)

\*If line set is greater than 20 ft. (6.10m) add this amount. If line set is less than 20 ft. (6.10m) subtract this amount

## A - Leak Testing

- 1 - Attach gauge manifold and connect a drum of dry nitrogen to center port of gauge manifold.

## **⚠ CAUTION**

**When using dry nitrogen, a pressure reducing regulator must be used to prevent excessive pressure in gauge manifold, connecting hoses, and within the system. Regulator setting must not exceed 150 psig (1034 kpa). Failure to use a regulator can cause equipment failure resulting in injury.**

- 2 - Open high pressure valve on gauge manifold and pressurize line set and indoor coil to 150 psig (1034 kPa).

- 3 - Check lines and connections for leaks.

*NOTE-If electronic leak detector is used, add a trace of refrigerant to the nitrogen for detection by leak detector.*

- 4 - Release nitrogen pressure from the system, correct any leaks and recheck.

## B - Evacuating the System

- 1 - Attach gauge manifold. Connect vacuum pump (with vacuum gauge) to center port of gauge manifold. With both manifold service valves open, start pump and evacuate indoor coil and refrigerant lines.

## **⚠ IMPORTANT**

**A temperature vacuum gauge, mercury vacuum (U-tube), or thermocouple gauge should be used. The usual Bourdon tube gauges are not accurate enough in the vacuum range.**

## **⚠ IMPORTANT**

**The compressor should never be used to evacuate a refrigeration or air conditioning system.**

- 2 - Evacuate the system to 29 inches (737mm) vacuum. During the early stages of evacuation, it is desirable to stop the vacuum pump at least once to determine if there is a rapid loss of vacuum. A rapid loss of vacuum would indicate a leak in the system and a repeat of the leak testing section would be necessary.
- 3 - After system has been evacuated to 29 inches (737mm), close gauge manifold valves to center port, stop vacuum pump and disconnect from gauge manifold. Attach an upright nitrogen drum to center port of gauge manifold and open drum valve slightly to purge line at manifold. Break vacuum in system with nitrogen pressure by opening manifold high pressure valve. Close manifold high pressure valve to center port.
- 4 - Close nitrogen drum valve and disconnect from gauge manifold center port. Release nitrogen pressure from system.
- 5 - Connect vacuum pump to gauge manifold center port. Evacuate system through manifold service valves until vacuum in system does not rise above 29.7 inches (754mm) mercury (5mm absolute pressure) within a 20-minute period after stopping vacuum pump.
- 6 - After evacuation is complete, close manifold center port, and connect refrigerant drum. Pressurize system slightly with refrigerant to break vacuum.

## C - Charging

If the system is completely void of refrigerant, the recommended and most accurate method of charging is to weigh the refrigerant into the unit according to the total amount shown on the unit nameplate and in table 6.

**TABLE 6**

10AC REFRIGERANT CHARGE	
Unit	Refrigerant Charge R-22
10AC12	4 lbs. 4 oz.
10AC18	4 lbs. 12 oz.
10AC24	5 lbs. 5 oz.
10AC30	5 lbs. 9 oz.
10AC36	5 lbs. 12 oz.
10AC42-1	9 lbs. 3 oz.
10AC42-2	7 lbs. 13 oz.
10AC48	8 lbs. 13 oz.
10AC60	11 lbs. 2 oz.

If weighing facilities are not available or if unit is just low on charge, the following procedure applies.

Refer to Table 3 on page 3 for factory oil charge.

**1 - Expansion Valve Systems**

The following procedures are intended as a general guide for use with expansion valve systems only. For best results, indoor temperature should be between 70 °F and 80 °F. Outdoor temperature should be 60 °F or above. Slight variations in charging temperature and pressure should be expected. Large variations may indicate a need for further servicing.

**! IMPORTANT**

The following procedure requires accurate readings of ambient (outdoor) temperature, liquid temperature and liquid pressure for proper charging. Use a thermometer with accuracy of +2 °F and a pressure gauge with accuracy of ±5 PSIG.

- 1 - Connect gauge manifold. Connect an upright R-22 drum to center port of gauge manifold.
- 2 - Record outdoor ambient temperature.
- 3 - Operate indoor and outdoor units. Allow outdoor unit to run until system pressures stabilize.
- 4 - Make sure thermometer well is filled with mineral oil before checking liquid line temperature.

5 - Place thermometer in well and read liquid line temperature. Liquid line temperature should be a few degrees warmer than the outdoor air temperature. Table 7 shows how many degrees warmer the liquid line temperature should be.

Add refrigerant to make the liquid line temperature cooler.

Recover refrigerant to make the liquid line temperature warmer.

**TABLE 7**

APPROACH METHOD - EXPANSION VALVE SYSTEMS	
Model	Liquid Temp Minus Ambient Temp. (°F)
10AC12	1±1
10AC18	5±1
10AC24	4±1
10AC30	8±1
10AC36	10±1
10AC42-1	16±1
10AC42-2	7±1
10AC48	7±1
10AC60	10±1

6 - When unit is properly charged liquid line pressures should approximate those given in table 8.

**! IMPORTANT**

Use table 8 as a general guide for performing maintenance checks. Table 8 is not a procedure for charging the system. Minor variations in these pressures may be expected due to differences in installations. Significant deviations could mean that the system is not properly charged or that a problem exists with some component in the system. Used prudently, table 8 could serve as a useful service guide.

**TABLE 8**

NORMAL OPERATING PRESSURES																		
OUTDOOR COIL ENTERING AIR TEMPERATURE	10AC12		10AC18		10AC24		10AC30		10AC36		10AC42-1		10AC42-2		10AC48		10AC60	
	LIQ. ± 10	SUC. ± 10	LIQ. ± 10	SUC. ± 10	LIQ. ± 10	SUC. ± 10	LIQ. ± 10	SUC. ± 10	LIQ. ± 10	SUC. ± 10	LIQ. ± 10	SUC. ± 10	LIQ. ± 10	SUC. ± 10	LIQ. ± 10	SUC. ± 10	LIQ. ± 10	SUC. ± 10
	PSIG	PSIG	PSIG	PSIG	PSIG	PSIG	PSIG	PSIG	PSIG	PSIG	PSIG	PSIG	PSIG	PSIG	PSIG	PSIG	PSIG	PSIG
65° F (RFCII)	126	52	137	56	142	59	154	58	158	58	166	56	159	61	146	60	152	55
75° F (RFCII)	149	64	161	64	168	66	181	64	185	64	191	65	186	67	167	66	179	62
85° F (RFCII)	178	71	188	71	194	72	210	70	218	70	223	71	204	70	200	71	206	67
95° F (RFCII)	208	78	216	77	220	78	238	75	250	75	255	77	246	76	231	75	233	72
105° F (RFCII)	236	83	252	80	253	81	276	78	283	77	294	80	280	79	261	79	278	75
65° F (TXV)	126	58	133	60	140	63	151	61	164	60	163	58	160	63	146	63	147	59
75° F (TXV)	149	70	157	68	164	70	178	67	191	66	188	67	188	69	167	69	174	66
85° F (TXV)	178	77	184	75	190	76	207	73	218	72	220	73	202	73	200	74	201	71
95° F (TXV)	208	79	214	77	221	78	238	75	251	74	255	78	242	76	231	76	233	73
105° F (TXV)	236	84	250	80	254	81	276	78	292	77	294	81	288	80	261	80	278	76

## 2 - RFCII Systems

The following procedures are intended as a general guide for use with RFCII systems only. For best results, indoor temperature should be between 70 °F and 80 °F. Outdoor temperature should be 60 °F or above. Slight variations in charging temperature and pressure should be expected. Large variations may indicate a need for further servicing.

### **! IMPORTANT**

The following procedure requires accurate readings of ambient (outdoor) temperature, liquid temperature and liquid pressure for proper charging. Use a thermometer with accuracy of  $\pm 2$  °F and a pressure gauge with accuracy of  $\pm 5$  PSIG.

- 1 - Connect gauge manifold. Connect an upright R-22 drum to center port of gauge manifold.
- 2 - Operate indoor and outdoor units in cooling mode. Allow outdoor unit to run until system pressures stabilize.
- 3 - Make sure thermometer well is filled with mineral oil before checking liquid line temperature.
- 4 - Read liquid line pressure and convert to condensing temperature using temperature/pressure conversion chart.  
Condensing temperature (read from gauges) should be a few degrees warmer than the liquid line temperature.
- 5 - Place thermometer in well and read liquid line temperature. Table 9 shows how much warmer the condensing temperature should be.  
Add refrigerant to make the liquid line temperature cooler.  
Recover refrigerant to make the liquid line temperature warmer.
- 6 - When unit is properly charged liquid line pressures should approximate those given in table 8.

## V - MAINTENANCE

At the beginning of each heating or cooling season, the system should be cleaned as follows:

### A - Outdoor Unit

- 1 - Clean and inspect condenser coil. (Coil may be flushed with a water hose).
- 2 - Condenser fan motor is prelubricated and ports are sealed with plugs. No further lubrication is required. Oiling ports can be accessed for lubrication after extended operation by removing plugs. Securely seal after servicing.
- 3 - Visually inspect all connecting lines, joints and coils for evidence of oil leaks.

### **! IMPORTANT**

If insufficient heating or cooling occurs, the unit should be gauged and refrigerant charge checked.

### B - Indoor Coil

- 1 - Clean coil if necessary.
- 2 - Check connecting lines, joints and coil for evidence of oil leaks.
- 3 - Check condensate line and clean if necessary.

### C - Indoor Unit

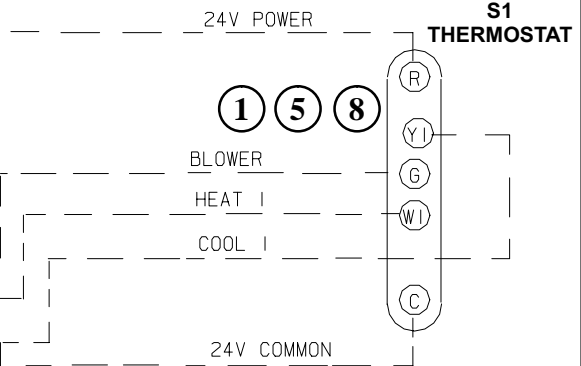
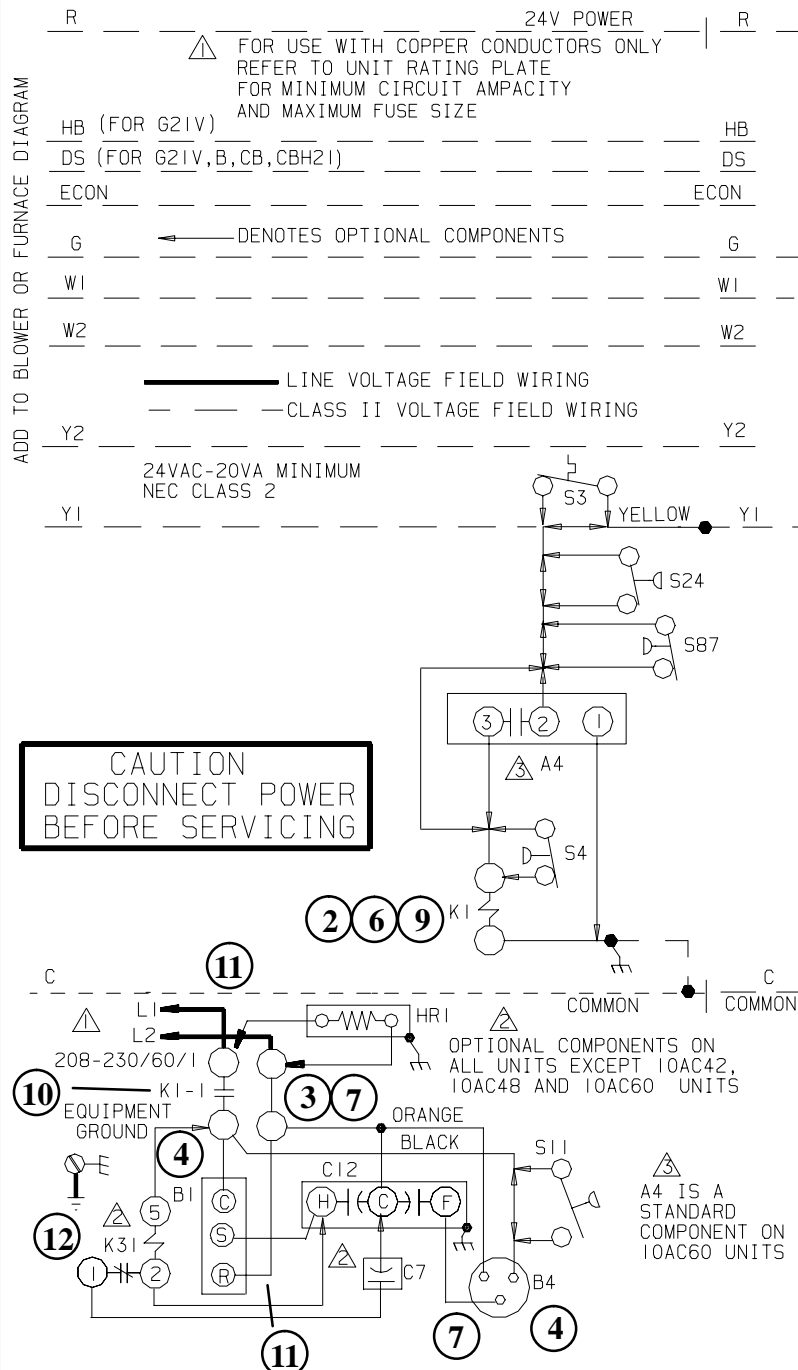
- 1 - Clean or change filters.
- 2 - Check blower motor for debris. Blower motors are prelubricated and sealed. No further lubrication required
- 3 - Adjust blower speed for cooling. The static pressure drop over the coil should be checked to determine the correct blower CFM. Refer to Lennox Engineering Handbook for Static Pressure and CFM tables.
- 4 - Check all wiring for loose connections.
- 5 - Check for correct voltage at unit.
- 6 - Check amp-draw on blower motor.  
Unit nameplate \_\_\_\_\_ Actual \_\_\_\_\_.

TABLE 9

Outdoor Temp. (°F)	SUBCOOLING METHOD								
	Liquid Subcooling ( $\pm 1$ °F)								
	10AC12	10AC18	10AC24	10AC30	10AC36	10AC42-1	10AC42-2	10AC48	10AC60
60	9	11	14	13	15	15	17	20	17
65	8	11	14	12	14	15	17	19	16
70	7	10	13	12	13	14	16	19	16
75	7	10	13	11	12	14	16	18	15
80	6	9	12	11	11	13	15	18	15
85	6	9	12	10	10	13	15	17	14
90	5	8	11	10	9	12	15	17	14
95	4	8	11	10	8	12	14	16	13
100	4	7	10	9	6	11	13	15	13
105	3	6	10	8	5	10	12	15	12
110	3	6	9	8	4	10	11	14	11
115	2	5	8	7	2	9	10	13	10

**VI - WIRING DIAGRAM AND SEQUENCE OF OPERATION**

**10AC OPERATING SEQUENCE**



**OPERATING SEQUENCE**

- A-10AC Operation Sequence**  
 This is the sequence of operation for 10AC units. The sequence is outlined by numbered steps which correspond to circled numbers on the adjacent diagram.
- NOTE-The thermostat used may be electromechanical or electronic.*
- Cooling-No Start Components:**
- 1- Cooling demand initiates at Y1 in the thermostat.
  - 2- Compressor contactor K1 is energized
  - 3- K1-1 N.O. closes energizing terminal "C" of compressor (B1) and condenser fan motor (B4).
  - 4- Compressor (B1) and condenser fan motor (B4) begin immediate operation.
- End of Cooling Demand:**
- 5- Cooling demand is satisfied.
  - 6- Contactor K1 is de-energized.
  - 7- K1-1 opens, and compressor (B1) and condenser fan motor (B4) are de-energized and stop immediately.
- Cooling-With Start Components (Standard on 10AC42, 10AC48 and 10AC60)**
- 8- Cooling demand initiates at Y1 in the thermostat.
  - 9- Compressor contactor K1 is energized
  - 10-K1-1 N.O. closes energizing terminal "C" of compressor (B1) and condenser fan motor (B4).
  - 11-Terminal R is powered by L2 through the contactor. It is powered at all times. Terminal S is powered by the start capacitor and the H side of the dual capacitor.
  - 12-As the compressor nears full speed, potential relay K31 is energized (terminals 5-2) and potential relay contacts 1-2 open and the start capacitor is taken out of the circuit.

KEY	DESCRIPTION
A4	CONTROL-TIMED OFF
B1	COMPRESSOR
B4	MOTOR-FAN
C7	CAPACITOR-COMP. START
C12	CAPACITOR-DUAL
HR1	HEATER-COMPRESSOR
K1-1, 2	CONTACTOR-COMPRESSOR
K31	RELAY-HARD START KIT
S3	LIMIT-LOW COMP. TEMP.
S4	LIMIT-HI PRESS. COMP.
S11	SWITCH-PRESS. LO AMB KIT
S24	SWITCH-LOSS OF CHARGE
S87	SWITCH-LO PRESS. LIMIT

**LENNOX®** Industries Inc. WIRING DIAGRAM 9/92 11/92

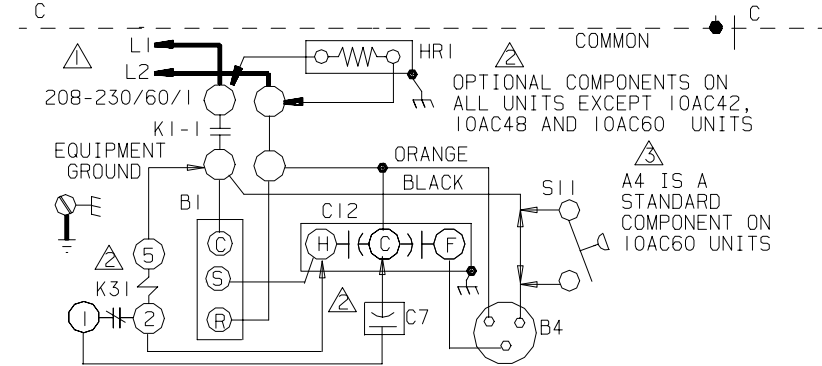
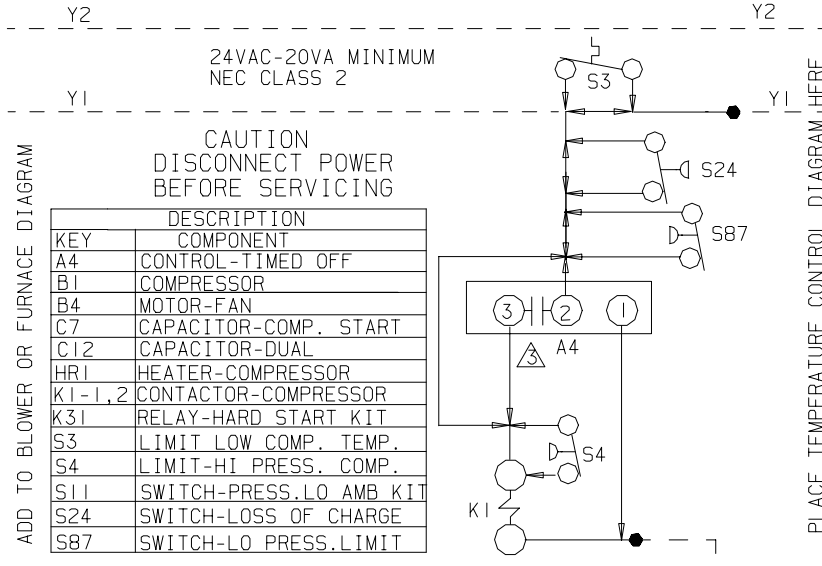
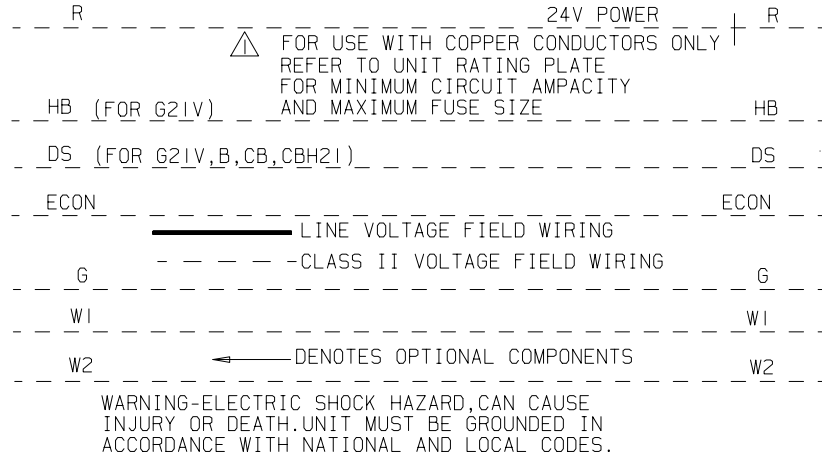
COOLING UNITS-CONDENSING UNITS

10AC12-1-P	10AC30-1,2-P	10AC48-1-P
10AC18-1-P	10AC36-1-P	10AC60-1-P
10AC24-1-P	10AC42-1,2-P	

COOLING UNITS-SEC. B

Supersedes Form No. New Form No. 529, 633W

# TYPICAL 10AC WIRING DIAGRAM



<b>LENNOX</b> ® Industries Inc.		WIRING DIAGRAM	9/92 11/92
COOLING UNITS-CONDENSING UNITS			
10AC12-1-P	10AC30-1,2-P	10AC48-1-P	
10AC18-1-P	10AC36-1-P	10AC60-1-P	
10AC24-1-P	10AC42-1,2-P		
COOLING UNITS-SEC. B			
Supersedes Form No.		New Form No.	
		529,633W	