



© 2006 Lennox Industries Inc.
Dallas, Texas, USA

GAS UNITS
KITS AND ACCESSORIES

Technical
Publications
Litho U.S.A.

505,178M
02/06

**IGNITION CONTROL
REPLACEMENT KIT**

**INSTALLATION INSTRUCTIONS FOR IGNITION CONTROL CONVERSION KIT 19W94
USED WITH 80MGF(X)-1/3 AND 80MGF(X)/G24M(X)-2/4/6 UNITS**

⚠ WARNING

This conversion kit is to be installed by a qualified Lennox service technician or other qualified agency in accordance with the manufacturer's instructions, all codes and requirements of the authority having jurisdiction in the USA, and the requirements of the CSA-B149 installation codes in Canada. If the information in these instructions is not followed exactly, a fire or explosion may result causing property damage, personal injury or loss of life. The qualified agency performing this work assumes responsibility for this conversion.

**ELECTROSTATIC DISCHARGE (ESD)
Precautions and Procedures**

⚠ CAUTION

Electrostatic discharge can affect electronic components. Take precautions during furnace installation and service to protect the furnace's electronic controls. Precautions will help to avoid control exposure to electrostatic discharge by putting the furnace, the control and the technician at the same electrostatic potential. Neutralize electrostatic charge by touching hand and all tools on an unpainted unit surface, such as the gas valve or blower deck, before performing any service procedure.

Shipping & Packing List

Package 1 of 1 contains:

- 1 - Replacement ignition control 100980-01 with adapter plate
- 1 - Ignition cable
- 1 - Wiring harness - 80MGF(X) -1/3
(the "P166" 15 pin female plug has female pins)
- 1 - Wiring harness - 80MGF(X)/G24M(X)-2/4/6
(the "P166" 15 pin female plug has male pins)
- 2 - Wire nuts - 80MGF(X) -1/3
- 4 - #8-18x1/2 self-drill self-tap screws
- 2 - Wiring schematic stickers
- 1 - Diagnostic sticker
- 4 - Unused hole stickers
- 1 - Unit conversion sticker
- 7 - Wires - 80MGF(X) -1/3

02/06

NOTE - This kit contains components for converting ignition controls for two different series of units. Use only the components required for the particular unit(s) being converted.

Shipping Damage

Check all components for shipping damage. Consult last carrier immediately if damage is found.

Application - 80MGF(X)-1/3

This portion of the ignition control replacement kit converts 80MGF(X)-1/3 units from Ram control (3MC-4) 20J8001 to integrated control 100980-01.

Installation - 80MGF(X)-1/3

⚠ WARNING

Before installing or servicing unit, be sure ALL power to unit is OFF. More than one disconnect switch may be present. Electrical shock can cause personal injury or death!

- 1 - Set the thermostat to the lowest setting. Shut off gas supply and disconnect electrical power from the unit.
- 2 - Remove access door and turn gas valve knob to **OFF**.

**Removal of Ram Control and related wiring
(Refer to figure 2)**

- 1 - Disconnect the ignition cable from the ignitor and control board and discard.
- 2 - Cut brown wire (from blower harness plug to terminal "H-OUT" of control board) near control board.
- 3 - Disconnect all wires from control board.
- 4 - Separate the connection of the main wire harness. Cut brown wire (main plug terminal "5") near main plug (on the blower harness plug side of main plug). Disconnect white wire (main plug terminal "9") from transformer. Discard control board side of main plug harness.
- 5 - Disconnect remaining wires from transformer and discard.
- 6 - Remove and discard existing control board.

505,178M



Installation of replacement control and related wiring (Refer to figure 3)

- 1 - Cover any unused blower access panel holes with the small blank stickers provided with the replacement control.
- 2 - Using four provided screws, secure control board to blower access panel in proximity to location of original control board. Orient control board so that connection plug is in the top right corner (unit in upflow position).
- 3 - Connect provided six wires as follow:
 - a - Connect blue wire from 24V side of transformer to "24VAC HOT" terminal on control board.
 - b - Connect yellow wire from 24V side of transformer to "24VAC RTN" terminal on control board.
 - c - Connect green/yellow wire from transformer mounting screw to "GROUND" terminal of control board.
 - d - Connect black wire from "120V" terminal on transformer to "120VAC TX" terminal on control board.
 - e - Connect one white wire (the one with a terminal on each end) from common terminal of transformer to "120VAC RTN" terminal on control board.
 - f - Connect the other white wire from common 120V power supply connection to "120VAC RTN" terminal on control board.
- 4 - Connect one side of door switch to "120VAC HOT" terminal on control board. Connect the other side to the hot side of the 120V power supply.
- 5 - Connect provided ignition cable to control board and ignitor.

IMPORTANT - DO NOT INCLUDE IGNITION LEAD IN ANY GROUP OF BUNDLED WIRES. ROUTE IGNITION LEAD SEPARATELY.

- 6 - Select the proper adapter wire harness. The 15 pin "P166" female plug of the harness contains female pins.
- 7 - Connect the male plug of 80MGF(X)-1/3 adapter wire harness to female plug on control board.
- 8 - Connect the female plug of the 80MGF(X)-1/3 adapter wire harness to male plug of main unit wire harness.
- 9 - Connect the wire from pin "7" of female plug of 80MGF(X)-1/3 adapter wire harness to "120VAC RTN" terminal of control board.
- 10 - Connect the wire from pin "9" of female plug of 80MGF(X)-1/3 adapter wire harness to "CMB BL WR" terminal of control board.
- 11 - Connect with a wire nut (provided), brown wire from pin "5" of female plug of 80MGF-1/3 adapter wire harness to one of the brown wires coming out of the blower harness plug.
- 12 - Connect with a wire nut (provided), brown wire from pin "8" of male plug of 80MGF-1/3 adapter wire

harness to the other brown wire coming out of the blower harness plug.

13 - Blower Speed and Continuous Fan Connections:

Existing units with continuous low speed fan operation:

Do not install provided continuous fan jumper as shown in figure 3 and do not change existing low speed tap connection. Make the ACB HEAT and ACB COOL connections as shown.

Existing units with no continuous low speed fan operation:

Connect provided continuous fan jumper between control board terminals ACB HEAT and ACB LOW to obtain continuous fan operation on the heating speed when thermostat is set to FAN ON and there is no heating or cooling demand. Make the ACB HEAT and ACB COOL connections as shown in figure 3.

- 14 - Remove the existing wiring diagram sticker, located on the inside surface of the unit access panel, and replace with 535,330W wiring diagram sticker (provided).
- 15 - Replace the existing diagnostic sticker on the blower access panel using the replacement sticker provided.
- 16 - Affix the provided unit conversion sticker beside the existing rating plate located on the inside vestibule area of cabinet.

Application - 80MGF(X)/G24M(X)-2/4/6

This portion of the ignition control replacement kit converts 80MGF(X)/G24M(X)-2/4/6 units from Ram control (3MC5-01) 33J6201 to integrated control 100980-01.

Installation - 80MGF(X)/G24M(X)-2/4/6

WARNING

Before installing or servicing unit, be sure ALL power to unit is OFF. More than one disconnect switch may be present. Electrical shock can cause personal injury or death!

- 1 - Set the thermostat to the lowest setting. Shut off gas supply and disconnect electrical power from the unit.
- 2 - Remove access door and turn gas valve knob to **OFF**.

Removal of Ram Control and related wiring

- 1 - Disconnect the ignition cable from the ignitor and control board and discard.
- 2 - Mark and disconnect all wires from control board.
- 3 - Separate the connection of the main wire harness at the control board plug.
- 4 - Remove and discard existing control board.

Installation of replacement control and related wiring (Refer to figure 4)

- 1 - Cover any unused blower access panel holes with the small blank stickers provided.
- 2 - Using four provided screws, secure control board to blower access panel in proximity to location of original control board. Orient control board so that connection plug is in the top right corner (unit in upflow position).
- 3 - Reconnect existing wires as follows:
 - a - **On 80MGF(X)-2/4/6 units** - Reconnect blue wire from 24V side of transformer to "24VAC HOT" terminal on control board.
On G24M(X)-2/4/6 units - Reconnect blue wire from circuit breaker to "24VAC HOT" terminal on control board.
 - b - Reconnect yellow wire from 24V side of transformer to "24VAC RTN" terminal on control board.
 - c - Reconnect green/yellow wire from transformer mounting screw to "GROUND" terminal of control board.
 - d - Reconnect black wire from "120V" terminal on transformer to "120VAC TX" terminal on control board.
 - e - Reconnect the white wire from common 120V power supply connection to "120VAC RTN" terminal on control board.
- 4 - Connect one side of door switch to "120VAC HOT" terminal on control board. Connect the other side to the hot side of the 120V power supply.
- 5 - Connect provided ignition cable to control board and ignitor.

IMPORTANT - DO NOT INCLUDE IGNITION LEAD IN ANY GROUP OF BUNDLED WIRES. ROUTE IGNITION LEAD SEPARATELY.

- 6 - Select the proper adapter wire harness. The 15 pin "P166" female plug of the harness contains male pins.
- 7 - Connect the male plug of 80MGF(X)/G24M(X)-2/4/6 adapter wire harness to female plug on control board.
- 8 - Connect the female plug of the 80MGF(X)/G24M(X)-2/4/6 adapter wire harness to male plug of main unit wire harness.
- 9 - Connect the wire from pin "2" of female plug of 80MGF(X)/G24M(X)-2/4/6 adapter wire harness to "120VAC RTN" terminal of control board.
- 10 - Connect the wire from pin "1" of female plug of 80MGF(X)/G24M(X)-2/4/6 adapter wire harness to "CMB BL WR" terminal of control board.
- 11 - Connect the blower heating speed tap to "ACB HEAT" terminal on control board, the low speed tap

to "ACB LOW" terminal and the cooling speed tap to "ACB COOL" terminal. See figure 6 for blower speed tap.

- 12 - Remove existing wiring diagram sticker, located on the inside surface of unit access panel, and replace with 535,329W wiring diagram sticker (provided).
- 13 - Replace the existing diagnostic sticker on the blower access panel using the provided replacement diagnostic sticker.
- 14 - Affix provided unit conversion sticker beside existing rating plate located on the inside vestibule area of cabinet.

Control Board Operation

Integrated Blower and Ignition Control 100980-01

The integrated control controls blower operation and fan off timings, allows for thermostat connections, controls ignition and provides two diagnostic LEDs with a memory recall button. To interpret the LEDs, see the diagnostic codes section near the end of these instructions or the diagnostic codes sticker provided in the kit. To check operation sequence refer to the flow charts at the end of this instruction.

Blower Speed / Timing Adjustments

IMPORTANT - Turn electrical power off before making any adjustments.

Continuous Speed

Systems using a cooling thermostat subbase may operate continuous blower through the Fan-ON switch of the thermostat. For continuous blower with a system without a cooling subbase, a toggle switch must be installed between the "R" and "G" of unit thermostat connections. Refer to figure 5 (80MGF(X)-1/3 units) or figure 6 (80MGF(X)/G24M(X)-2/4/6 units) for factory-connected blower speed taps.

80MGF(X)-1/3 units (See figure 3)

Some units may have existing continuous low speed fan connected independently of the control board. If this is the case, do not connect continuous fan jumper. If this is not the case, install continuous fan jumper as outlined in step 13 of 80MGF(X)-1/3 installation section to obtain continuous blower operation on the heating speed.

WARNING - Do not install jumper if continuous low speed is installed, either at control board ACB terminal or to a separate circuit controlled by terminal G of the thermostat. Damage to the control board and/or blower motor may result.

80MGF(X)/G24M(X)-2/4/6 units

The blower will operate continuously on low speed when connected to the control board as outlined in step 11 of 80MGF(X)/G24M(X)-2/4/6 installation section.

Fan On and Off timings

The fan on time of 45 seconds is not adjustable. Fan off time (time that the blower operates after the heating demand has been satisfied) can be adjusted by moving the jumper on the integrated control board. The replacement integrated control is shipped with a factory fan off setting of 180 seconds. Fan off time will affect comfort and is adjustable to satisfy individual applications. See figure 1.

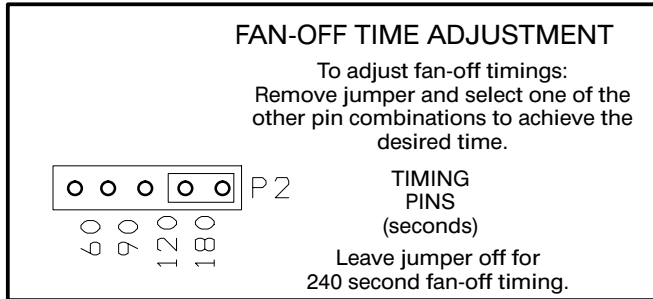

FIGURE 1

Start-Up

BEFORE LIGHTING smell all around the appliance area for gas. Be sure to smell next to the floor because some types of gas are heavier than air and will settle on the floor.

Use only your hand to move the gas control knob. Never use tools. If the knob will not move by hand, do not try to repair it, call a qualified service technician. Force or attempted repair may result in a fire or explosion.

To place unit in operation

- 1 - Make sure thermostat is set below room temperature and power is turned off to unit.
- 2 - This appliance is equipped with an ignition device which automatically lights the pilot burner. **DO NOT** try to light the pilot burner by hand.
- 3 - Turn knob on gas valve to **OFF**. Do not force.
- 4 - Wait 15 minutes to clear out any gas. If you then smell gas, immediately call your gas supplier from a neighbor's phone. Follow the gas supplier's instructions. If you do not smell gas go to next step.
- 5 - Turn knob on gas valve to **ON**.
- 6 - Turn on all electrical power to unit.
- 7 - Set thermostat to above room temperature.
- 8 - Check gas line supply pressure with unit operating. The minimum pressure as shown on the name rating plate must be available. Then check and adjust manifold pressure to the value indicated on the unit rating plate.
- 9 - Set heat anticipator to 0.65 for Honeywell gas valve and 0.50 for WhiteRodgers gas valve.
- 10 - Run unit through a minimum of three complete cycles to check for normal operation.
- 11 - Set thermostat to desired setting.
- 12 - Replace access panel.

WIRING DIAGRAM FOR 80MGF(X)-1/3 WITH INTEGRATED CONTROL (100980-01)

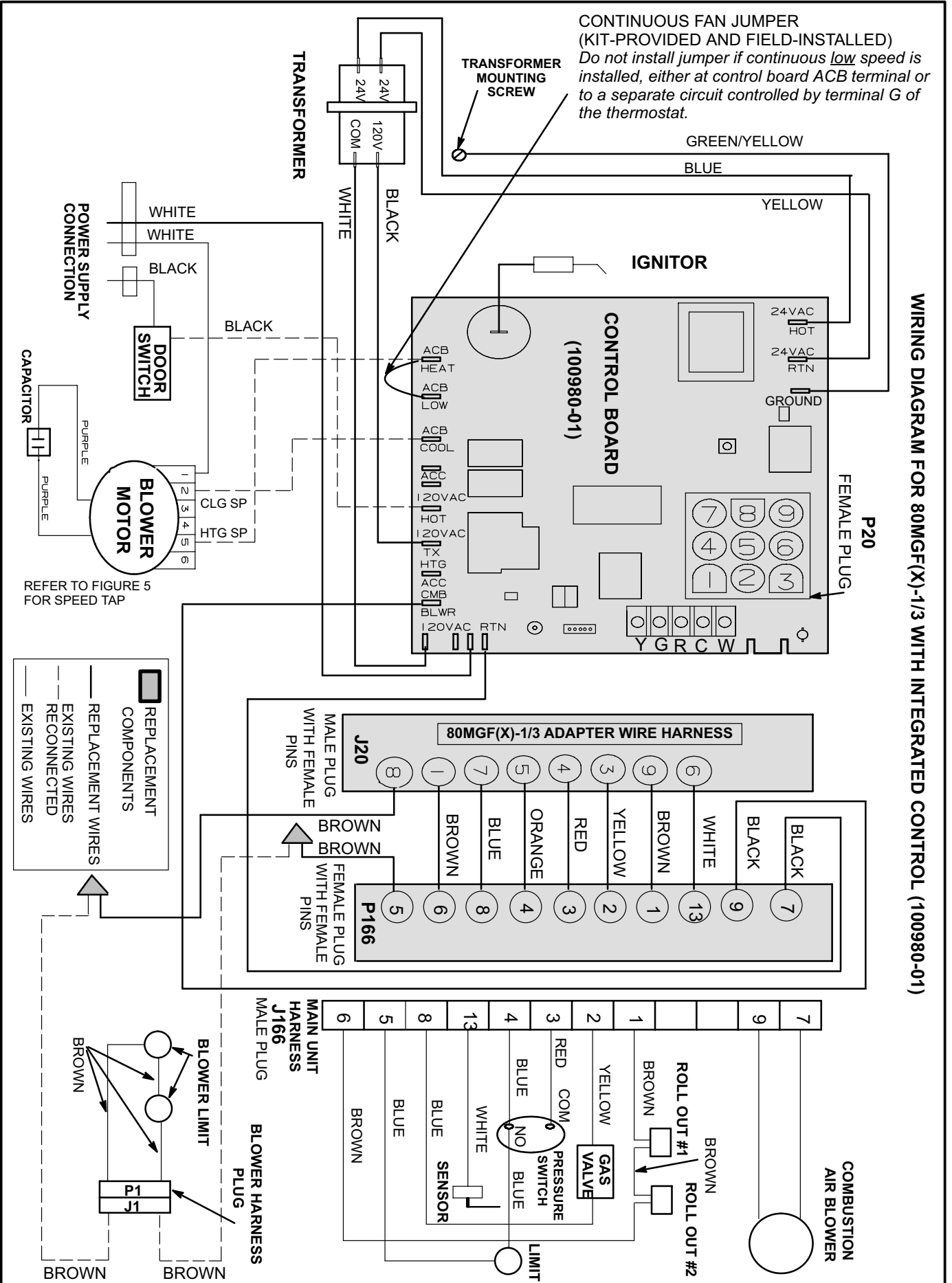

FIGURE 3

WIRING DIAGRAM FOR 80MGF(X)/G24M(X)-2/4/6 WITH INTEGRATED CONTROL (100980-01)

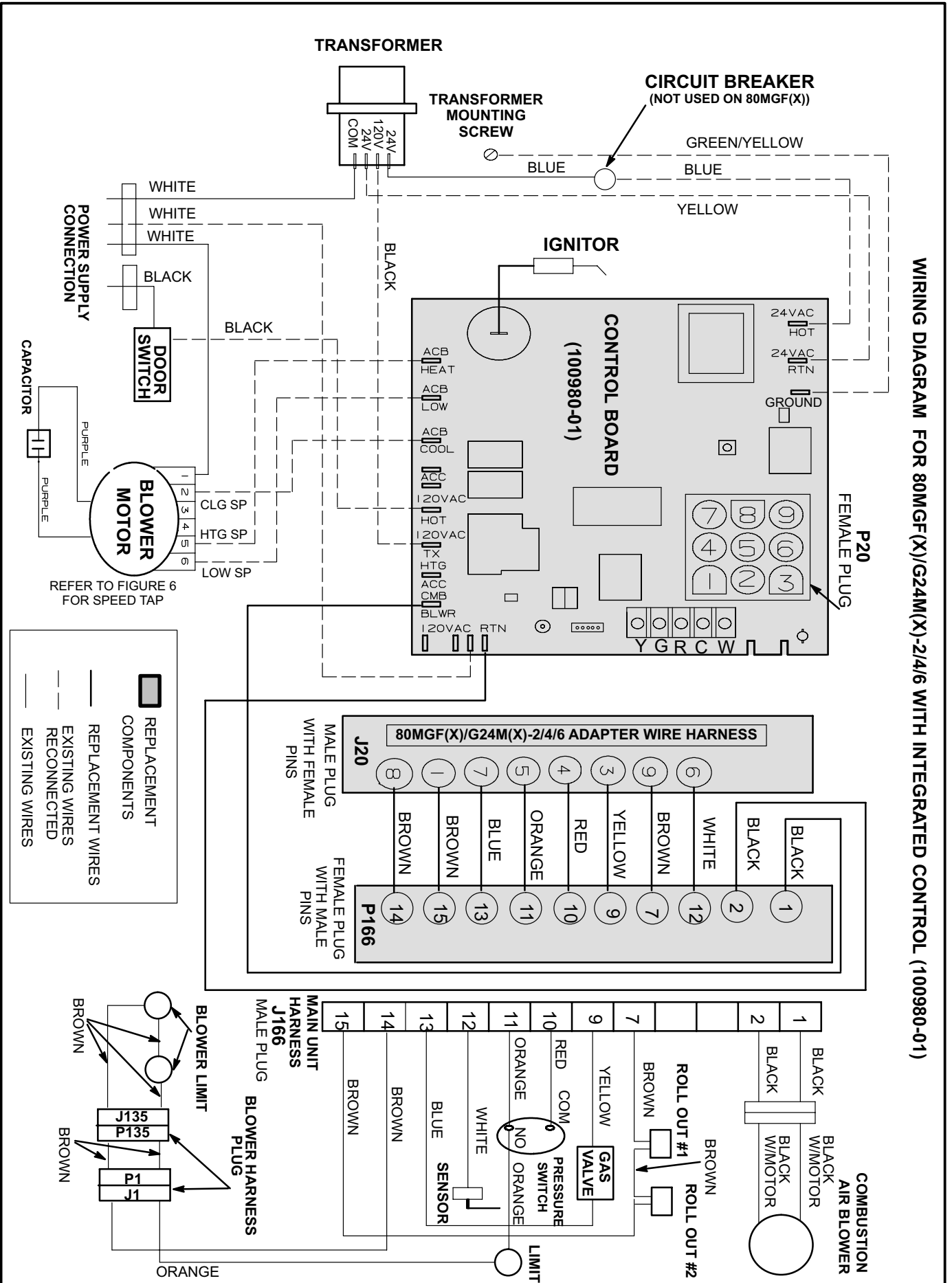

FIGURE 4

WIRING DIAGRAM FOR 80MGF(X)-1/3 UNITS CONVERTED FROM RAM CONTROL BOARD 3MC-4 (20J8001) TO INTEGRATED CONTROL (100980-01)

KEY	DESCRIPTION
A3	CONTROL, BURNER, IGNITION
B3	MOTOR, BLOWER
B6	MOTOR, COMBUSTION AIR BLOWER
C4	CAPACITOR, BLOWER MOTOR
GVI	VALVE, GAS
J1	JACK, SECONDARY LIMIT
J20	JACK, GAS
J43	JACK, BLOWER MOTOR
J166	JACK, HARNESS-INTERFACE
P1	PLUG, SECONDARY LIMIT
P20	PLUG, GAS
P43	PLUG, BLOWER MOTOR
P166	PLUG, HARNESS-INTERFACE
S10	LIMIT, PRIMARY, GAS
S18	SWITCH, COMB. AIR BLWR PROVE
(1)S21	LIMIT, SECONDARY
(2)S21	LIMIT, SECONDARY
S43	SWITCH, LOW PRESS. GAS
(1)S47	SWITCH, FLAME ROLLOUT
(2)S47	SWITCH, FLAME ROLLOUT
S51	SWITCH, DOOR INTERLOCK
T1	TRANSFORMER, CONTROL

BLOWER SPEED CHART			
UNIT	FACTORY CONNECTED SPEED TAP		MOTOR SPEEDS AVAILABLE
	COOL	HEAT	
02-45/60	2	4	4
03-60/75	2	4	4
04-75, 3/4-100	2	4	5
04/5-100/120	2	5	5
02-75	2	3	4
04/5-140, 3/4-120	2	3	5

BLOWER SPEED SELECTION				
HI ← → LO				
SPEED TAP	2	3	4	5
	2	3	4	5

IMPORTANT-TO PREVENT MOTOR BURNOUT, NEVER CONNECT MORE THAN ONE MOTOR LEAD TO ANY ONE CONNECTION.

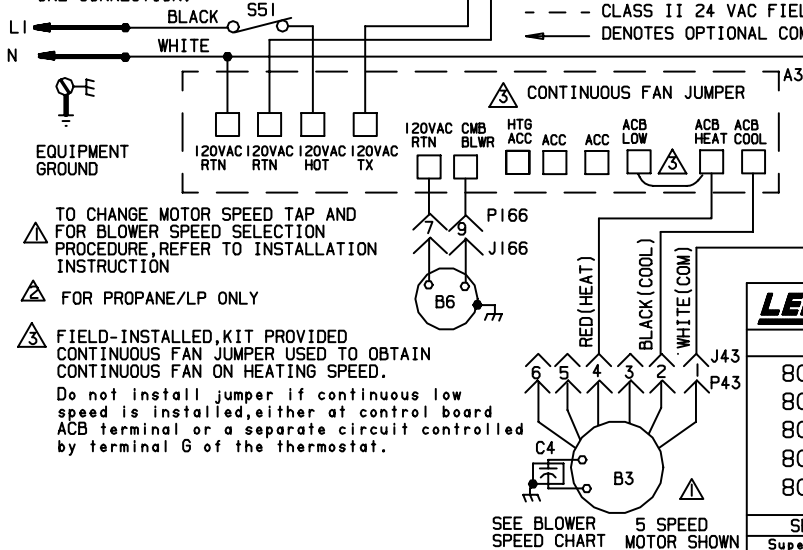

NOTE- IF ANY WIRE IN THIS APPLIANCE IS REPLACED, IT MUST BE REPLACED WITH WIRE OF LIKE SIZE, RATING AND INSULATION THICKNESS.

WARNING- ELECTRIC SHOCK HAZARD, CAN CAUSE INJURY OR DEATH. UNIT MUST BE GROUNDED IN ACCORDANCE WITH NATIONAL AND LOCAL CODES.

SET THERMOSTAT HEAT ANTICIPATION FOR 80MGF SERIES UNITS AS FOLLOWS:
 HONEYWELL VALVE : 7
 WHITE ROGERS VALVE : 5

LENNOX Industries Inc		WIRING DIAGRAM	3/06
HEATING UNITS-GAS DSI			
80MGF2(X)-45, 60, 75-1, 3			
80MGF3(X)-60, 75-1, 3			
80MGF4(X)-75-1, 3			
80MGF3/4(X)-100, 120-1, 3			
80MGF4/5(X)-100, 120, 140-1, 3			
SECTION A		120/60/1	
Supersedes Form No. 532, 162W		New Form No. 535, 330W	

©2006 Lennox Industries Inc.

Litho CDN

FIGURE 5

**WIRING DIAGRAM FOR 80MGF(X)/G24M(X)-2/4/6 UNITS CONVERTED
FROM RAM CONTROL BOARD 3MC5-01 (33J6201)
TO INTEGRATED CONTROL (100980-01)**

KEY	DESCRIPTION
	COMPONENT
A3	CONTROL, BURNER, IGNITION
B3	MOTOR, BLOWER
B6	MOTOR, COMBUSTION AIR BLOWER
C3	CAPACITOR, COMB AIR BLOWER
C4	CAPACITOR, BLOWER MOTOR
CB8	CIRCUIT BREAKER
GV1	VALVE, GAS
J1	JACK, SECONDARY LIMIT
J20	JACK, GAS
J43	JACK, BLOWER MOTOR
JB4	JACK-COMB AIR BLOWER
J135	JACK, SECONDARY LIMIT
J166	JACK, HARNESS-INTERFACE
P1	PLUG, SECONDARY LIMIT
P20	PLUG, GAS
P43	PLUG, BLOWER MOTOR
PB4	PLUG-COMB AIR BLOWER
P135	PLUG, SECONDARY LIMIT
P166	PLUG, HARNESS-INTERFACE
S10	LIMIT, PRIMARY, GAS
S18	SWITCH, COMB. AIR BLWR PROVE
(1)S21	LIMIT, SECONDARY
(2)S21	LIMIT, SECONDARY
S43	SWITCH, LOW PRESS. GAS
(1)S47	SWITCH, FLAME ROLL OUT
(2)S47	SWITCH, FLAME ROLL OUT
S51	SWITCH, DOOR INTERLOCK
T1	TRANSFORMER, CONTROL

UNIT	FACTORY CONNECTED SPEED TAP			MOTOR SPEEDS AVAILABLE
	COOL	HEAT	CONT	
02-45/60	2	4	5	4
03-60/75	2	4	5	4
04-75, 3/4-100	2	4	5	5
04/5-100/120	2	5	6	5
02-75	2	3	5	4
04/5-140, 3/4-120	2	3	6	5

BLOWER SPEED SELECTION	
HI ← → LO	
SPEED TAP	2 3 4 5 6
	2 3 4 5 6

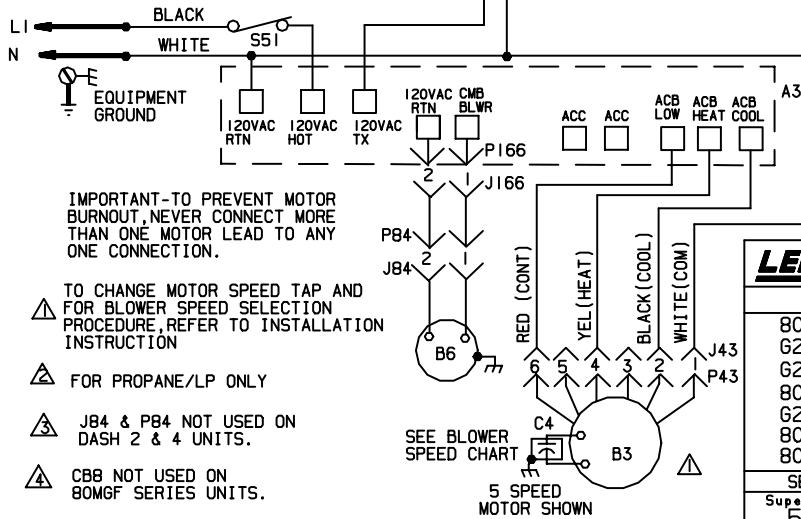

NOTE - IF ANY WIRE IN THIS APPLIANCE IS REPLACED, IT MUST BE REPLACED WITH WIRE OF LIKE SIZE, RATING AND INSULATION THICKNESS.

WARNING - ELECTRIC SHOCK HAZARD, CAN CAUSE INJURY OR DEATH. UNIT MUST BE GROUNDED IN ACCORDANCE WITH NATIONAL AND LOCAL CODES.

SET THERMOSTAT HEAT ANTICIPATION FOR G24M SERIES UNITS AS FOLLOWS:
 HONEYWELL VALVE :7
 WHITE ROGERS VALVE :5

LENNOX Industries Inc	WIRING DIAGRAM	3/06
HEATING UNITS-GAS DSI		
BOMGF, G24M2(X)-45, 60, 75-2, 4, 6		
G24M3(X)-60, 75-2, 4, 6		
G24M4(X)-75-2, 4, 6		
BOMGF, G24M3/4(X)-100, 120, -2, 4, 6		
G24M4/5(X)-100/120/140-2, 4, 6		
BOMGF3-75-2, 4, 6		
BOMGF4/5-140-2, 4, 6		
SECTION A	120/60/1	
Supersedes Form No.	532, 161W	New Form No.
		535, 329W

©2006 Lennox Industries Inc. Litho CDN

FIGURE 6

Diagnostic Codes

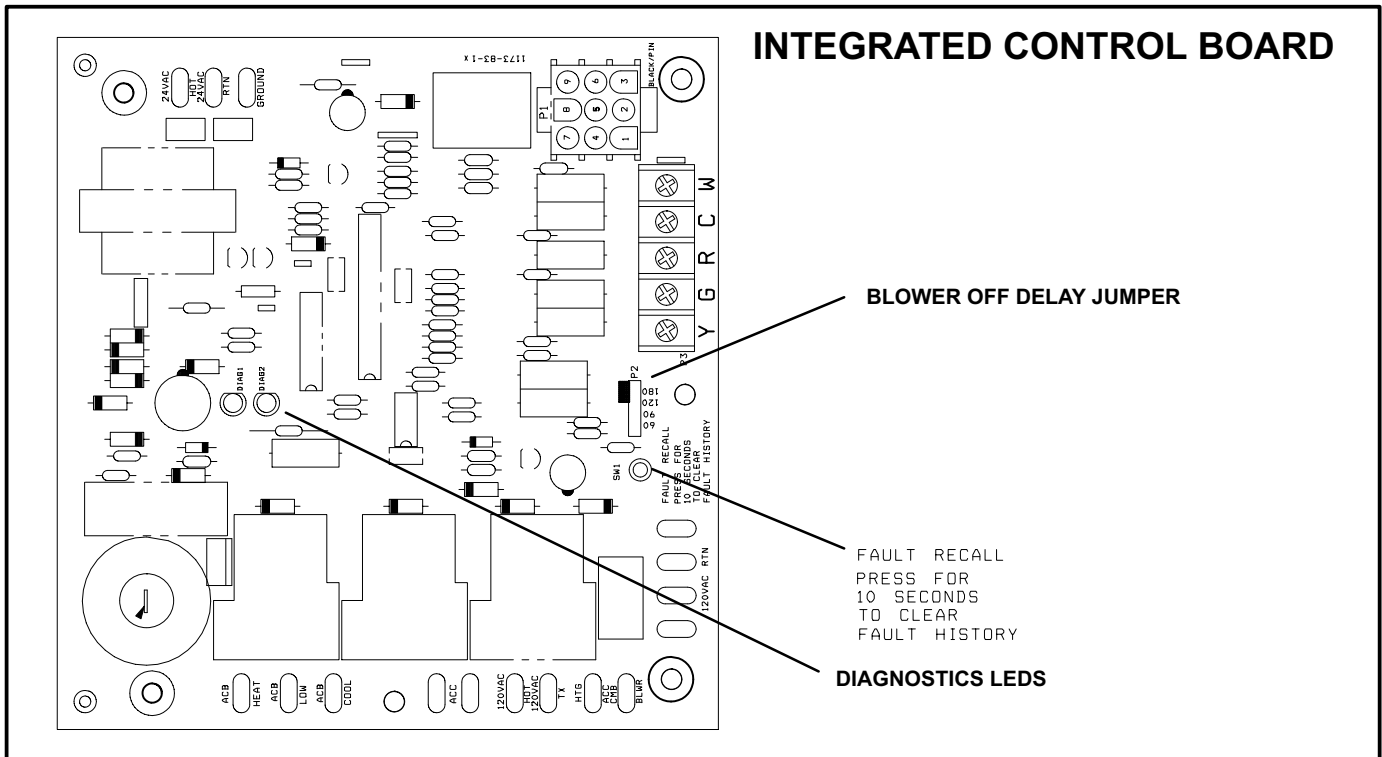

DSI BOARD DIAGNOSTIC PATTERNS	MODE INDICATION	REMEDY
DIAG 1 Flashing Together DIAG 2 Flashing Together	Normal Operation	None. Slow flashing LED signifies normal operation. Fast flashing LED indicates a heating demand.
DIAG 1 Flashing DIAG 2 On	Limit Switch Open	This LED pattern indicates that either the primary or secondary limit switch has opened. Both switches are auto-reset.
DIAG 1 Off DIAG 2 Flashing	Pressure Switch Open	This LED pattern indicates that the pressure switch opened during operation due to reduced flow of combustion products or a blocked condensate drain.
DIAG 1 Flashing Alternately DIAG 2 Flashing Alternately	Watchguard	The system is in Watchguard mode. Burners have failed to ignite.
DIAG 1 Flashing DIAG 2 Off	Flame Failure	This LED pattern indicates that a flame was sensed without power to the gas valve.
DIAG 1 On DIAG 2 Flashing	Flame Roll-Out	This LED pattern indicates that the flame roll-out switch has opened. Check continuity of switch and for blockage in heat exchanger. Manually reset switch.
DIAG 1 Continuously On DIAG 2 Continuously On	Control Board Failure	Remove power to reset control. Run cycle. Check control wiring and replace the EGC-1 control board, if necessary.

HEATING SEQUENCE OF OPERATION

NORMAL HEATING MODE

ABNORMAL HEATING MODE

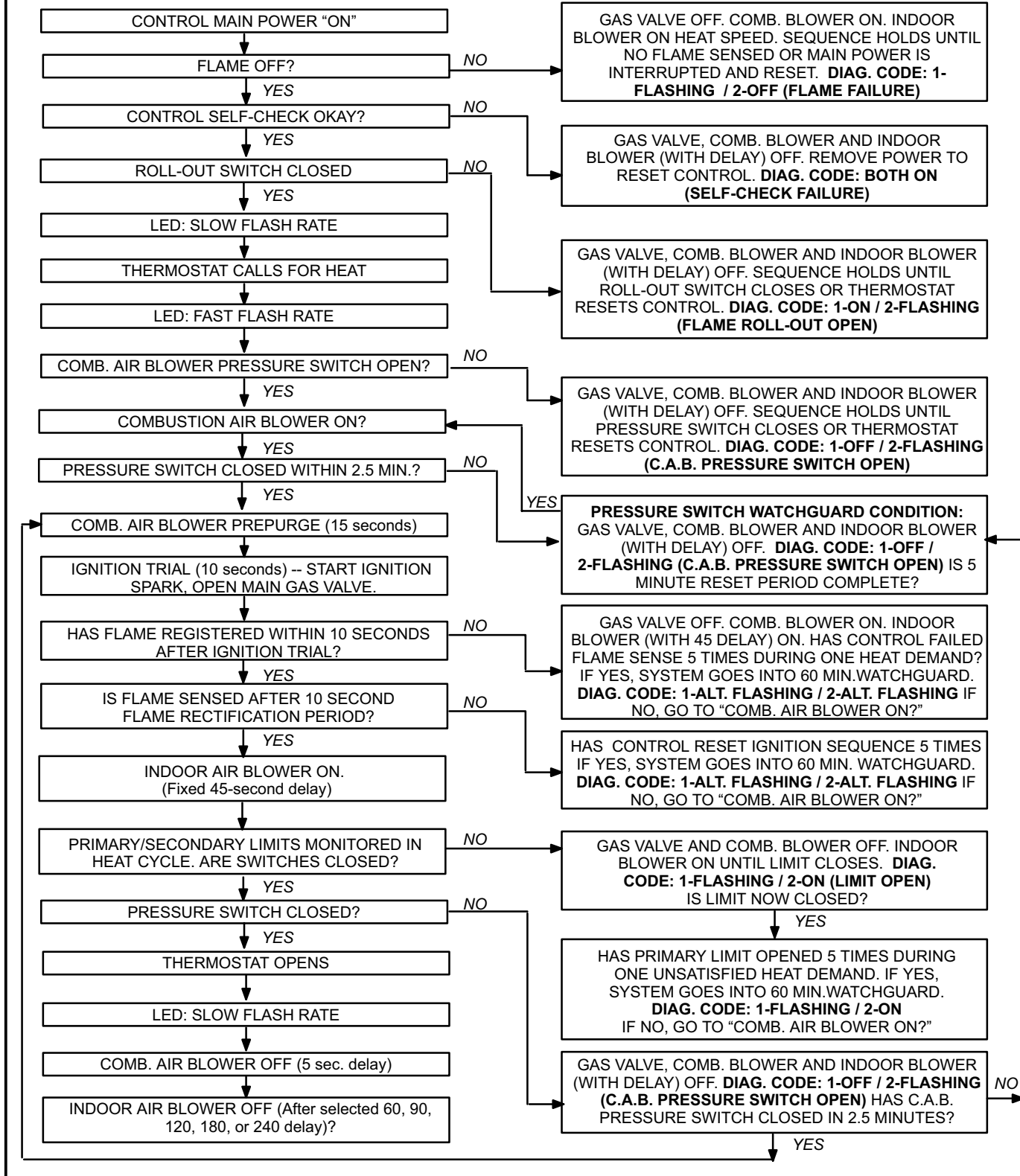

COOLING SEQUENCE OF OPERATION

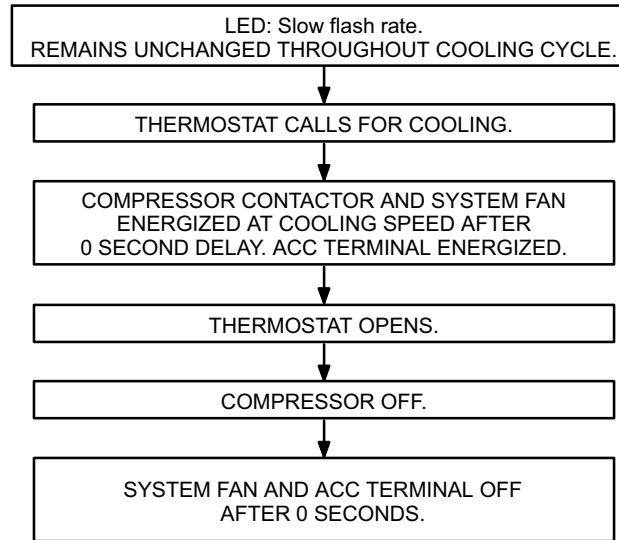

MANUAL FAN SEQUENCE OF OPERATION

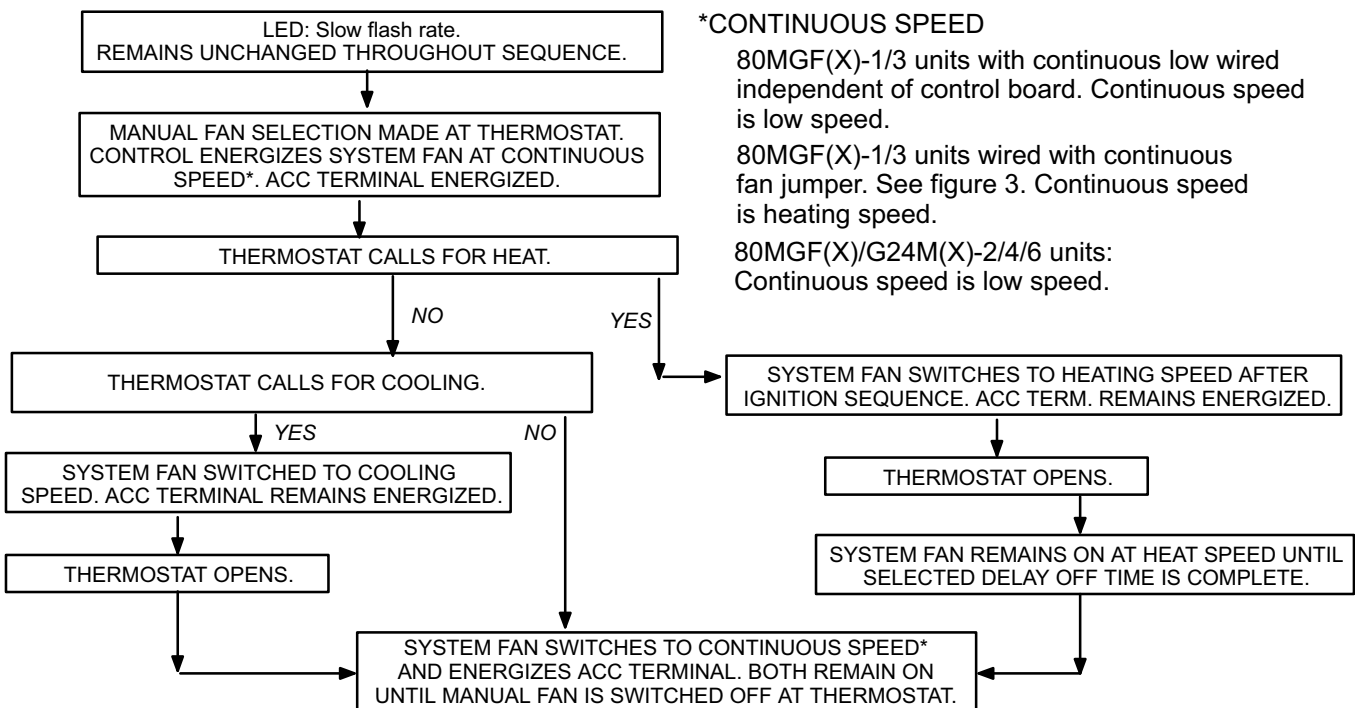

*CONTINUOUS SPEED

80MGF(X)-1/3 units with continuous low wired independent of control board. Continuous speed is low speed.

80MGF(X)-1/3 units wired with continuous fan jumper. See figure 3. Continuous speed is heating speed.

80MGF(X)/G24M(X)-2/4/6 units:
Continuous speed is low speed.