

## G12 AND G12E SERIES UNITS

### I - INTRODUCTION

Both G12 and G12E units are built with Duracurve heat exchangers formed out of cold rolled steel. These furnaces are atmospheric type burners that use pilot burners for ignition. The "G12" units use a standing pilot which burns continuously to ignite the main burners on each heating demand. This standing pilot uses a thermocouple for flame verification. In the event of pilot outage, the gas valve locks itself out

in response to the thermocouple.

"G12E" units use electronic ignition systems to light the pilot on each operating cycle (intermittent pilot). A protection circuit verifies pilot flame to allow main burner ignition. Main burner and pilot are extinguished during the off cycle. If the pilot gas does not light, the main gas valve will not open.

Only the G12E unit is approved for usage with the optional Vent Damper Assembly. The damper actuator electrically interlocks with the ignition system. The vent damper must be fully open before pilot ignition can occur.

In 1979 Lennox introduced new G12E furnaces featuring high CFM capabilities and low btu input. This permits the use of smaller furnaces in homes with lower heat loss while still providing adequate volumes of air for summer cooling. When compared to conventional furnaces these high/low units have a very low temperature rise range.

The units are manufactured for natural gas applications, but field propane field changeover kits are available.

Figure 1 shows a cutaway of a G12E-110.

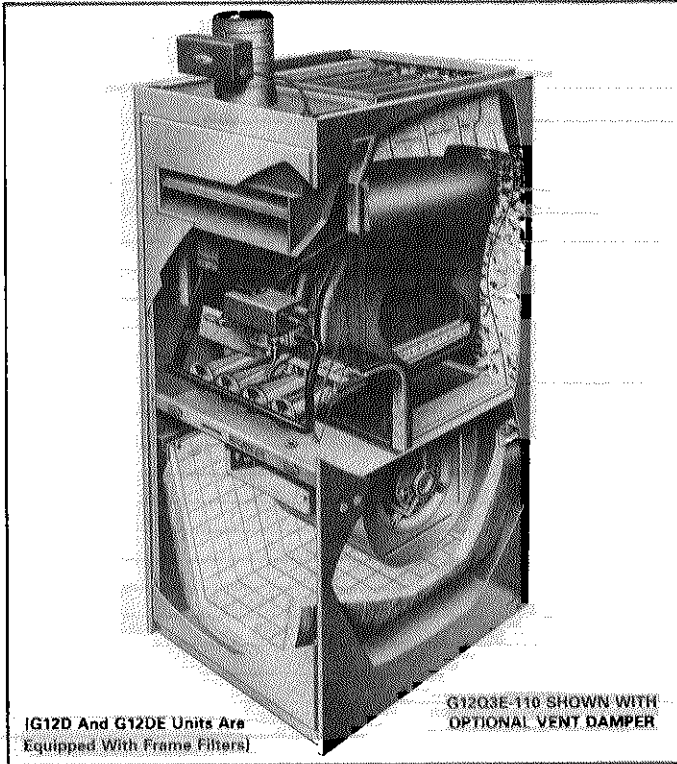

G12D And G12E Units Are Equipped With Frame Filters

G12Q3E-110 SHOWN WITH OPTIONAL VENT DAMPER

FIGURE 1

Model Number		G12D2-55	G12D2-82	G12D-110
Btuh input		55,000	82,000	110,000
Btuh bonnet output		44,000	65,600	88,000
Flue size (in.)		4	4	5
High static certified by A.G.A. (in. wg.)		.50	.50	.20
Gas piping size (I.P.S. in.)	Natural	1/2	1/2	1/2
	Propane	1/2	1/2	1/2
No. of burners		2	3	4
Blower wheel nom. diam. x width (in.)		9 x 7	9 x 7	9 x 9
Blower motor horsepower		1/5	1/5	1/8
Number and size of filters (in.)		1 - 16 x 25 x 1	1 - 16 x 25 x 1	1 - 16 x 25 x 1
Tons of cooling that can be added		1-1/2 or 2	1-1/2 or 2	1-1/2 or 2
Net weight (lbs.)		143	158	185
Number of packages in shipment		1	1	1
Electrical characteristics		120 volt - 60 hertz - 1 phase (All Units)		
Return Air Cabinet	Model No.	RA10-16-49	RA10-16-49	RA10-16-49
Air Shutter Kit (Nat. Gas Only)		LB-32077CA		

### UNIT INFORMATION

### A - Specifications

Model Number	G12Q3-82	G12Q3-110	G12Q4-110	G12Q3-137	G12Q4-137	G12Q5-137	G12Q5-165
Btuh input	82,000	110,000	110,000	137,000	137,000	137,000	165,000
Btuh bonnet output	65,600	88,000	88,000	109,600	109,600	109,600	132,000
Flue size (in.)	4	5	5	6 oval	6 oval	6 oval	6 oval
High static certified by A.G.A. (in. wg.)	.50	.50	.50	.50	.50	.50	.50
Gas piping size (I.P.S. in.)	1/2	1/2	1/2	1/2	1/2	1/2	3/4
No. of burners	2	3	3	3	3	3	3
Blower wheel nom. diam. x width (in.)	16 x 8	10 x 8	10 x 8	12 x 9	12 x 12	12 x 12	12 x 12
Blower motor horsepower	1/3	1/2	1/3	1/2	3/4	3/4	3/4
Net filter area (sq. ft.)	(6.6)	(6.6)	(8.9)	(8.9)	(8.9)	(9.2)	(9.2)
& cut size (in.)	40 x 28 x 1	40 x 28 x 1	52 x 28 x 1	52 x 28 x 1	52 x 28 x 1	54 x 28 x 1	54 x 28 x 1
Tons of cooling that can be added	2-1/2 or 3	3-1/2 or 4	2-1/2 or 3	3-1/2 or 4	4 or 5	4 or 5	4 or 5
Net weight (lbs.)	192	200	236	252	262	301	301
Number of packages in shipment	1	1	1	1	1	1	1
120 volt - 60 hertz - 1 phase (All Units)							
Return Air Cabinet	RA10-16-49	RA10-16-49	RA10-16-53	RA10-16-53	RA10-16-53	RA10-16-53	RA10-16-53
Net Weight (lbs.)	65	65	75	75	75	75	75
Air Shutter Kit (Nat. Gas Only)	LB-32077GA		LB-32077CB				

### II - UNIT INFORMATION

Model Number		RA10-16-49
Btuh input		137,000
Btuh bonnet output		109,600
Flue size (in.)		6 oval
High static certified by A.G.A. (in. wg.)		.50
Gas piping size (I.P.S. in.)	Natural	1/2
	Propane	1/2
No. of burners		3
Blower wheel nom. diam. x width (in.)		12 x 12
Blower motor horsepower		3/4
Net filter area (sq. ft.)		(9.2)
& cut size (in.)		54 x 28 x 1
Tons of cooling that can be added		4 or 5
Net weight (lbs.)		301
Number of packages in shipment		1
Electrical characteristics		120 volt - 60 hertz - 1 phase (All Units)
Return Air Cabinet	Model No.	RA10-16-49
Net Weight (lbs.)		65
Air Shutter Kit (Nat. Gas Only)		

Model Number		G12Q5E-75	G12D2E-92	G12Q3E-82	G12Q5E-100	G12DE-110	G12Q3E-110
Btuh input		75,000	82,000	82,000	100,000	110,000	110,000
Btuh bonnet output		59,000	65,600	65,600	80,000	88,000	88,000
Vent size (in.)		4	4	4	5	5	5
High static certified by A.G.A. (in. wg.)		.75	.50	.50	.75	.20	.50
Temperature rise range (degrees F)		20 — 50	70 — 100	70 — 100	20 — 50	70 — 100	70 — 100
Gas piping size (I.P.S. in.)	Natural	1/2	1/2	1/2	1/2	1/2	1/2
	Propane	1/2	1/2	1/2	1/2	1/2	1/2
No. of burners		3	3	3	4	4	4
Blower wheel nom. diam. x width (in.)		12 x 12	9 x 7	10 x 7	12 x 12	9 x 9	10 x 8
Blower motor horsepower		3/4	1/5	1/3	3/4	1/8	1/3
Net filter area (sq. ft.) & cut size		(8.9)52x28x1	1-16x28x1	(5.8)36x28x1	(8.9)52x28x1	1-16x25x1	(6.6)40x28x1
Tons of cooling that can be added		4 or 5	1-1/2 or 2	2, 2-1/2 or 3	4 or 5	----	2-1/2 or 3
Shipping weight (lbs.) — 1 pkg.		237	161	171	255	191	199
Electrical characteristics							
120 volt — 60 hertz — 1 phase (All Units)							
Return Air Cabinet (Opt.)	Model No.	RA10-16-53	RA10-16-49	RA10-16-49	RA10-16-53	RA10-16-49	RA10-16-49
	Shipping Wt. (lbs.)	56	54	54	56	54	54
Vent Damper Assembly — Optional		AFD4	AFD4	AFD4	AFD5	AFD5	AFD5
Air Shutter Kit (Nat. Gas Only)		LB-32077CA					

	110,000	137,000	137,000	137,000
Btuh input	88,000	109,600	109,600	109,600
Btuh bonnet output	5	6 oval	6 oval	6 oval
Vent size (in.)	.50	.50	.50	.50
High static certified by A.G.A. (in. wg.)	45 — 75	70 — 100	70 — 100	45 — 75
Temperature rise range (degrees F)	1/2	1/2	1/2	1/2
Gas piping size (I.P.S. in.)	1/2	1/2	1/2	1/2
No. of burners	.4	5	5	5
Blower wheel nom. diam. x width (in.)	10 x 8	10 x 8	12 x 9	12 x 12
Blower motor horsepower	1/2	1/3	1/3	3/4
Net filter area (sq. ft.) & cut size (in.)	(6.6) 40 x 28 x 1	(8.9) 52 x 28 x 1	(8.9) 52 x 28 x 1	(8.9) 52 x 28 x 1
Tons of cooling that can be added	3-1/2 or 4	2-1/2 or 3	3-1/2 or 4	4 or 5
Shipping weight (lbs.) — 1 pkg.	208	237	255	268
Electrical characteristics				
120 volts — 60 Hertz — 1 phase (All Models)				
No.	RA10-16-49	RA10-16-53	RA10-16-53	RA10-16-53
Shipping Wt. (lbs.)	54	56	56	56
	AFD5	AFD6	AFD6	AFD6
	LB-32077CA	LB-32077CB		

Model Number	
Btuh input	
Btuh bonnet output	
Vent size (in.)	
High static certified by A.G.A. (in. wg.)	
Temperature rise range (degrees F)	
Gas piping size (I.P.S. in.)	Natural
	Propane
No. of burners	
Blower wheel nom. diam. x width	
Blower motor horsepower	
Net filter area (sq. ft.) & cut size (in.)	
Tons of cooling that can be added	
Shipping weight (lbs.) — 1 pkg.	
Electrical characteristics	
Return Air Cabinet (Opt.)	Model No.
	Shipping Wt.
Vent Damper Assembly — Optional	
Air Shutter Kit (Nat. Gas Only)	

	G12Q3E-28	G12D2E-40	G12Q3E-40	G12Q4E-50	G12D2E-55	G12Q4E-60
Btuh input	28,000	40,000	40,000	50,000	55,000	60,000
Btuh Bonnet output	22,000	32,000	32,000	40,000	44,000	48,000
Vent size (in.)	3	4	4	4	4	4
High static certified by A.G.A. (in. wg.)	.75	.50	.85	.75	.50	.75
Temperature rise range (degrees F)	15 — 45	35 — 65	25 — 65	20 — 50	45 — 75	20 — 50
Gas piping size (I.P.S.)	1/2	1/2	1/2	1/2	1/2	1/2
	1/2	1/2	1/2	1/2	1/2	1/2
No. of burners	1	2	2	2	2	3
Blower wheel nom. diam. x width (in.)	10 x 7	9 x 7	10 x 7	10 x 8	9 x 7	10 x 8
Blower motor horsepower	1/3	1/5	1/3	1/2	1/5	1/2
Net filter area (sq. ft.) & cut size	(5.8)36x28x1	1-16x25x1	(5.8)36x28x1	(5.8)40x28x1	1-16x25x1	(6.6)40x28x1
Tons of cooling that can be added	2-1/2 or 3	1-1/2 or 2	2-1/2 or 3	3, 3-1/2 or 4	1-1/2 or 2	3, 3-1/2 or 4
Shipping weight (lbs.) — 1 pkg.	147	139	154	191	147	199
Electrical characteristics						
120 volt — 60 hertz — 1 phase (All Units)						
	RA10-16-49	RA10-16-49	RA10-16-49	RA10-16-49	RA10-16-49	RA10-16-49
Shipping Wt. (lbs.)	54	54	54	54	54	54
	AFD4	AFD4	AFD4	AFD4	AFD4	AFD4
	LB-32077CA					

Model Number	
Btuh input	
Btuh Bonnet output	
Vent size (in.)	
High static certified by A.G.A. (in. wg.)	
Temperature rise range (degrees F)	
Gas piping size (I.P.S.)	Natural
	Propane
No. of burners	
Blower wheel nom. diam. x width	
Blower motor horsepower	
Net filter area (sq. ft.) & cut size	
Tons of cooling that can be added	
Shipping weight (lbs.) — 1 pkg.	
Electrical characteristics	
Return Air Cabinet (Opt.)	Model No.
	Shipping Wt.
Vent Damper Assembly — Optional	
Air Shutter Kit (Nat. Gas Only)	

## B - Wiring

Field wiring is made at the unit junction box. The blower motor is factory wired with low speed (red) tap for heating and high speed tap (black) for cooling. Optional vent damper is wired by removing jumper plug and connecting in vent damper harness. See Figure 2.

Accessories must never be wired through fan control since it is possible to generate approximately 180 volts. This happens when the indoor blower relay is energized and the circuit is fed through the black motor lead. The motor acts as an auto transformer and generates the higher voltage through red leg to fan control. See Figure 3. Accessories must be wired through an isolated circuit and may be interconnected to blower operation with the use of a current sensing relay or sail switch.

## C - Installation Considerations

Installation of Lennox gas central furnaces must conform with local codes or in absence of local codes, with the National Fuel Gas Code (ANSI-Z223.1-1974). Air supply for combustion and ventilation must conform to the methods outlined in ANSI-Z223.1-1974. The extended warranty on heat exchanger will not apply if furnace is operated in a contaminated atmosphere, when supplied with 100% outdoor air or when installed down-stream from the cooling coil.

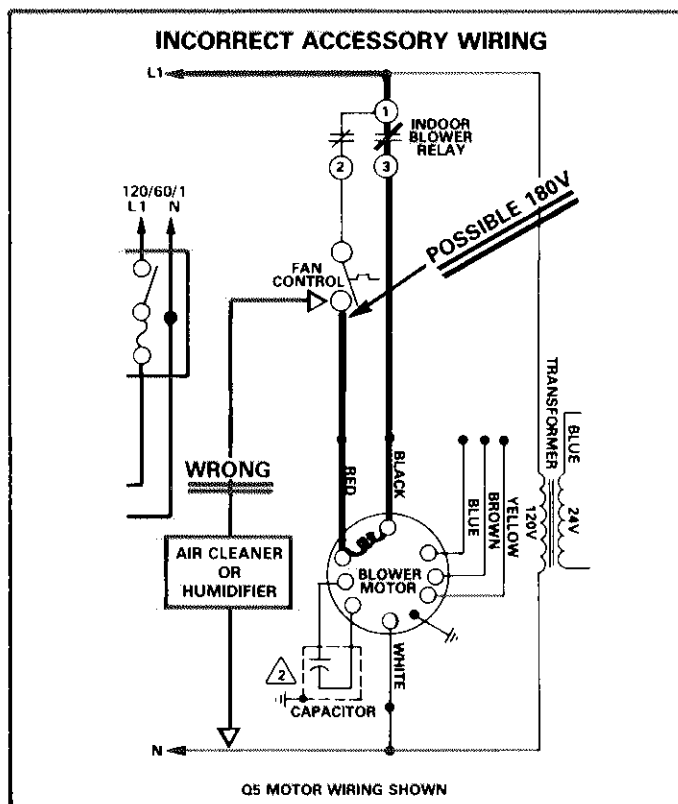

FIGURE 3

## III - UNIT COMPONENTS

### A - Control Box (Figure 4)

- 1 - Single-pole, double-throw indoor blower relay - 24 volt coil.

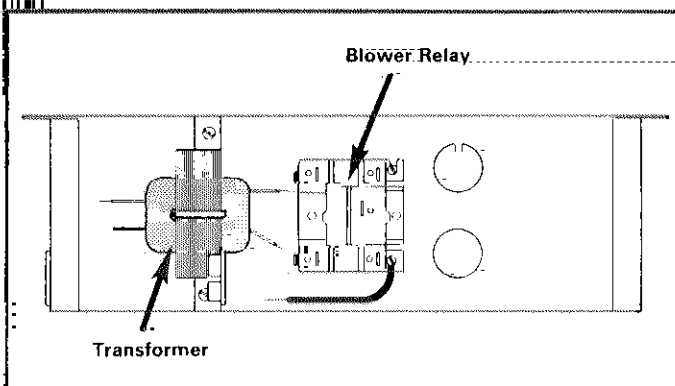

FIGURE 4

### B - Exploded View (Figure 5)

#### 1 - Fan/Limit Control

Three basic types of fan/limit controls are used: Camstat, Cemco and Honeywell. G12Q5E-137 models also use an auxiliary limit control. Do not adjust limits from factory settings.

Refer to Figure 6 for fan adjustment. Some units may employ a sure start type of fan control. As the main gas valve is energized, the fan control heater is activated to close the fan contacts after a short delay.

#### 2 - Manual Gas Shutoff Valve (Penn-Johnson Ignition System Only)

Furnaces equipped with the Penn-Johnson electronic ig-

## G12 AND G12E FIELD WIRING DIAGRAM

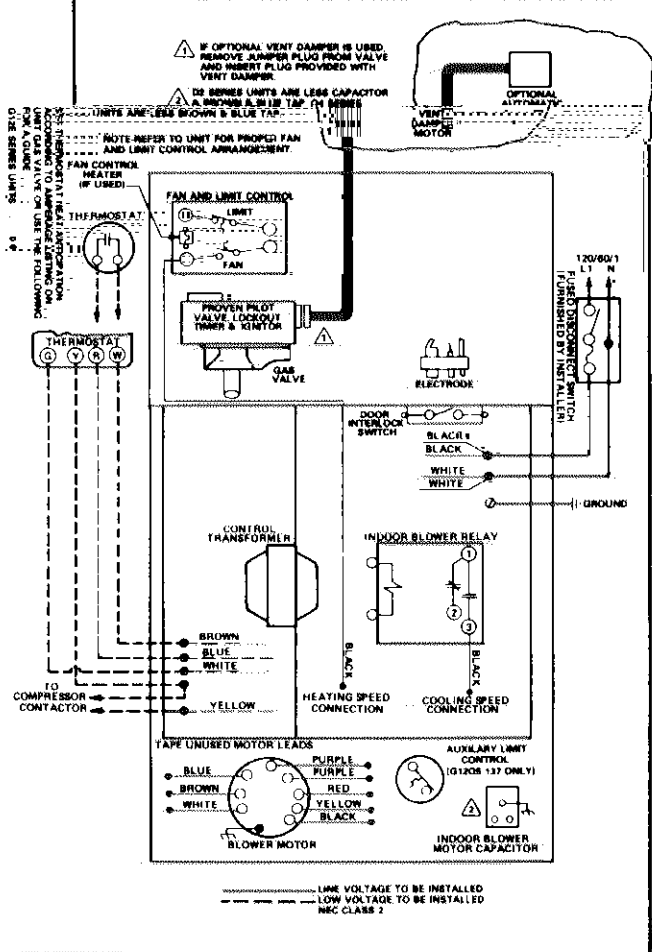
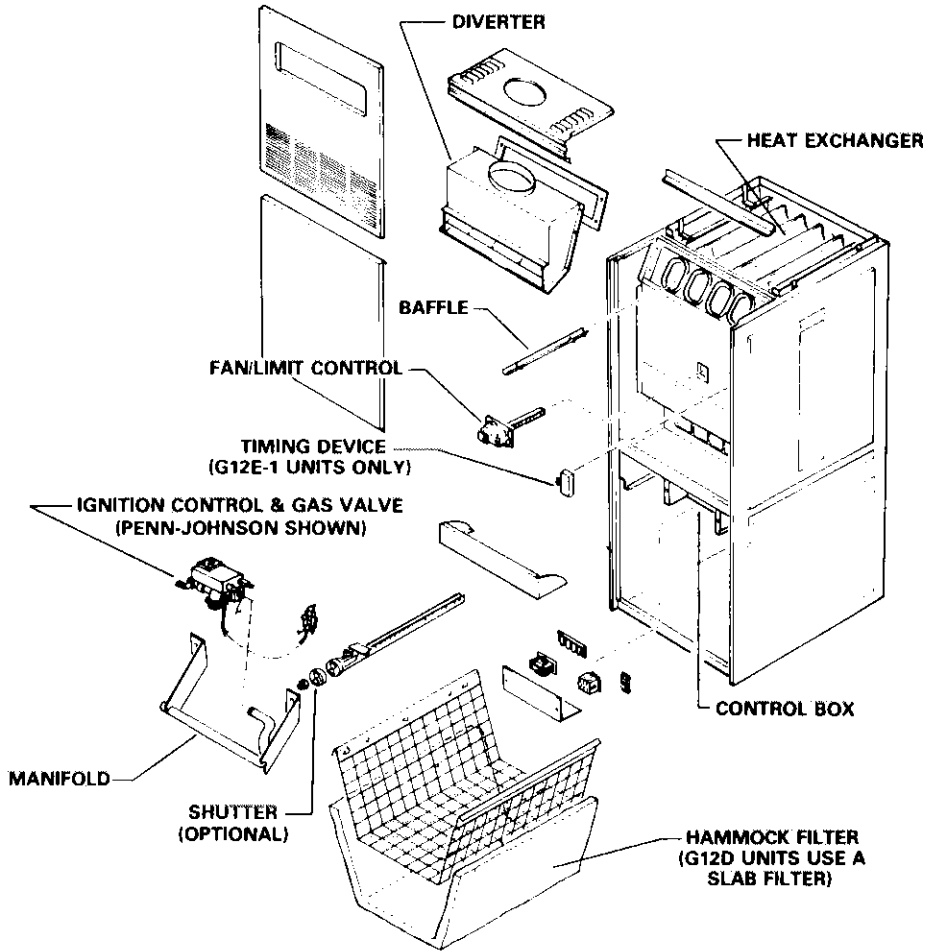
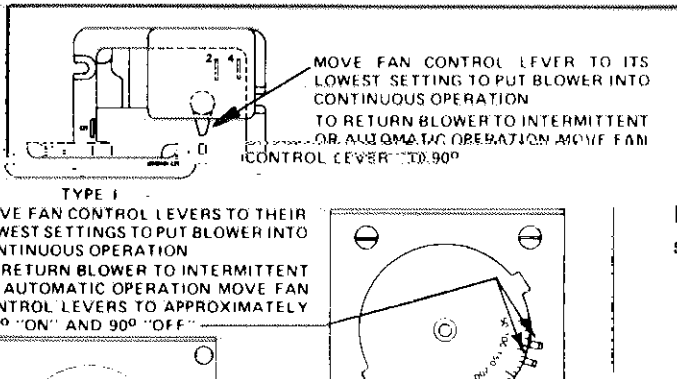

FIGURE 2

**G12E EXPLODED VIEW (PENN-JOHNSON SYSTEM SHOWN)**



**FIGURE 5**



Ignition system are equipped with a manual shutoff valve factory installed adjacent to the gas valve. This is an A.G.A. requirement to permit manual shutoff of gas supply. This shutoff valve must not be moved to the gas line external to the unit. If an external gas valve is used, it must be in addition to this valve.

**NOTE** - Robertshaw and White-Rodgers systems have shutoff at gas valve.

**3 - Electronic Ignition Components (G12E)**

Lennox has used three basic electronic ignition systems in G12E production. The systems are identified by the unit dash number. See Table 1. Refer to sections within this manual for a

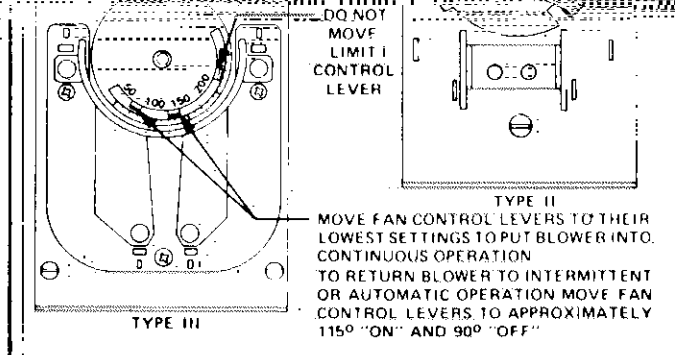

**FIGURE 6**

Additional information: These sections also show damper interface when used. Robertshaw systems the ignition control powers thermostat. When troubleshooting the 24 volt check the fuse internal to the ignition control. Ignition components consist of the gas assembly and ignition control. Dash 5 and 6 units use a redundant main gas valve. Two internal solenoids. Should one solenoid other assures gas shutoff. Some units incorporate a door interlock to de-

manual for a explain the valve. Note: On Robertshaw the "R" leg of the control circuit, ch... The individual valve, pilot as units plus high. This features to stick open, the... **4 - Door Interlock** Later producti

energize the control circuit whenever the blower access panel is removed.

**TABLE 1**

Dash Number	Ignition System
G12E-1 Series	Penn-Johnson (G60 - system 1)
G12E-2 Series	White Rodgers
G12E-3 Series	Robertshaw
G12E-4 Series	Penn-Johnson (G60 - system 2)
G12E-5 Series	Robertshaw
G12E-6 Series	Penn-Johnson (G60 - system 2)

### 5 - Air Shutters (If Used)

If desired an air shutter kit is available for natural gas installations. See unit specifications for kit numbers. The propane changeover kits include air shutters. Minor adjustments for flame lifting, burner noise, etc., may be necessary. Refer to Figure 7.

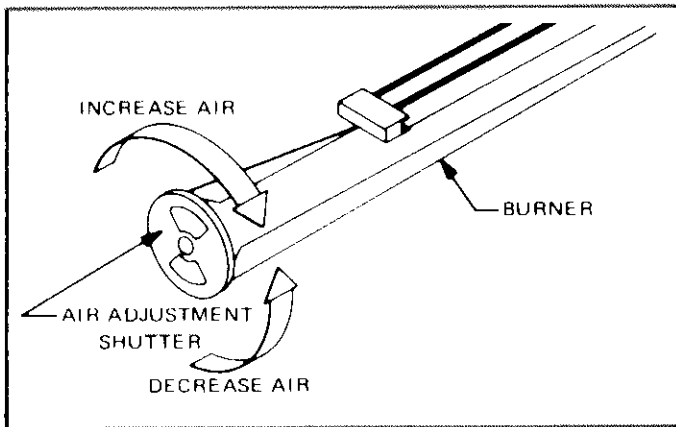

**FIGURE 7**

## IV - TEMPERATURE RISE (FIGURE 8)

The blower speed must be set to meet the proper air temperature rise listed on the unit rating plate. To measure this temperature rise, place plenum thermometers in warm air and return air plenums. Locate thermometer in warm air plenum where thermometer will not "see" heat exchanger, thus picking up radiant heat. Set thermostat to highest setting. After plenum thermometers have reached their highest and steadiest readings, subtract the two. The difference should be in the range listed on unit rating plate. If this temperature is low, decrease blower speed; if temperature is high, increase blower speed. Table 2 shows the speed selection charts for the various units.

**TABLE 2**

### BLOWER SPEED SELECTION

*IMPORTANT - TO PREVENT MOTOR BURNOUT, NEVER CONNECT MORE THAN ONE MOTOR LEAD TO ANY ONE CONNECTION. TAP UNUSED MOTOR LEADS SEPARATELY*

SPEED	BLOWER MOTOR LEAD		
	D2 OR Q4	Q3	Q5
LOW	RED	RED	RED
MEDIUM LOW	RED	YELLOW	YELLOW
MEDIUM	YELLOW	YELLOW	BLUE
MEDIUM HI	YELLOW	BROWN	BROWN
HIGH	BLACK	BLACK	BLACK

## V - SCHEMATIC WIRING DIAGRAM OPERATING SEQUENCE

Figure 9 illustrates a typical G12E unit with Penn-Johnson pilot ignitor.

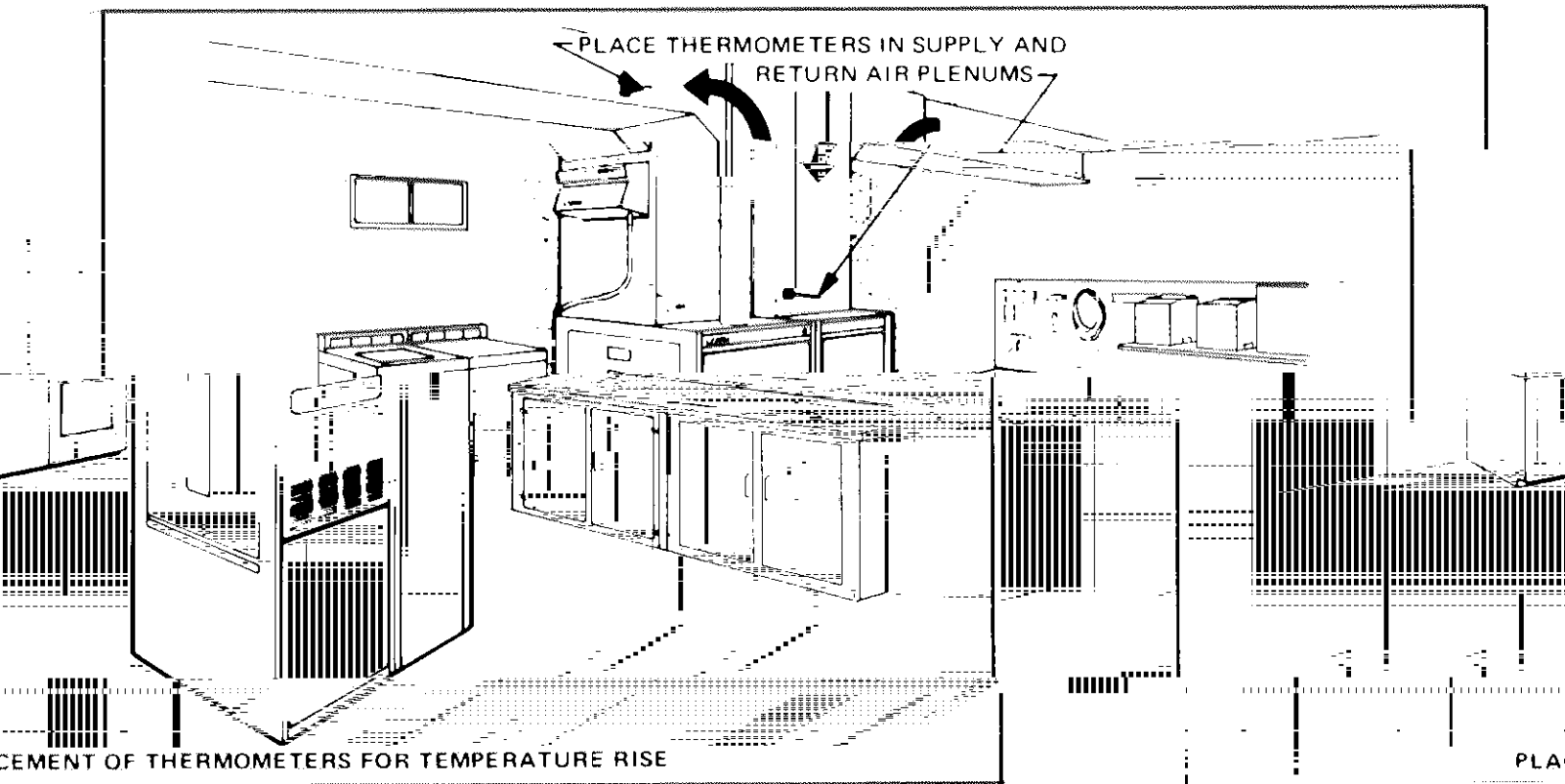

**FIGURE 8**

## TYPICAL G12E SEQUENCE OF OPERATION

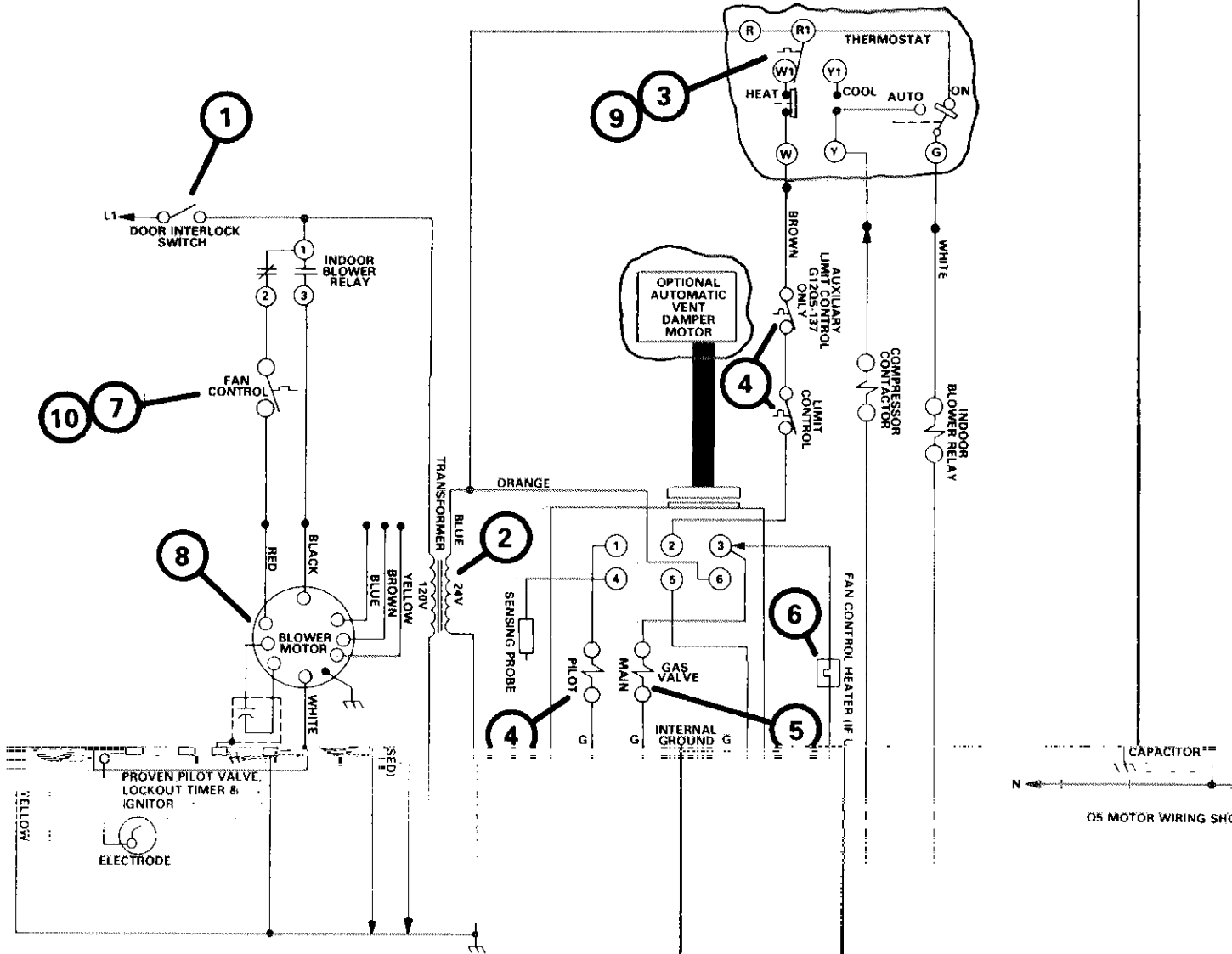

- 1 - Line potential feeds through the door interlock (if used). The blower access panel must be in place to energize the blower motor.
- 2 - Transformer provides 24 volt control power.
- 3 - On a heating demand the thermostat heating bulb makes.
- 4 - The control circuit feeds from "W" (white) control(s) to initiate pilot operation.
- 5 - After the pilot flame has proven, the main valve is energized. Main burners are ignited.
- 6 - As the main valve is energized, the fan control heater (if used) is also activated.
- 7 - After a short period, the heater provides sufficient heat to close the fan control contacts.
- 8 - This then energizes the blower motor on low speed.
- 9 - As the heating demand is satisfied, the thermostat heating bulb breaks. This de-energizes the ignition control, gas valve and fan control heater.
- 10 - The blower motor continues running until the furnace temperature drops below fan control setpoint.

- 1 - Line potential feeds through the door interlock (if used). The blower access panel must be in place to energize the blower motor.
- 2 - Transformer provides 24 volt control power.
- 3 - On a heating demand the thermostat heating bulb makes.
- 4 - The control circuit feeds from "W" (white) control(s) to initiate pilot operation.
- 5 - After the pilot flame has proven, the main valve is energized. Main burners are ignited.
- 6 - As the main valve is energized, the fan control heater (if used) is also activated.
- 7 - After a short period, the heater provides sufficient heat to close the fan control contacts.
- 8 - This then energizes the blower motor on low speed.
- 9 - As the heating demand is satisfied, the thermostat heating bulb breaks. This de-energizes the ignition control, gas valve and fan control heater.
- 10 - The blower motor continues running until the furnace temperature drops below fan control setpoint.

**FIGURE 9**